

# EVER *White*®

## Division 10 Packet

WRITING SURFACES. INSPIRED SPACES.



### Included Products



Magnetic Whiteboards



ULTImatte Projection Boards



Magnetic Resurfacing Panels



EVERGlass Whiteboards

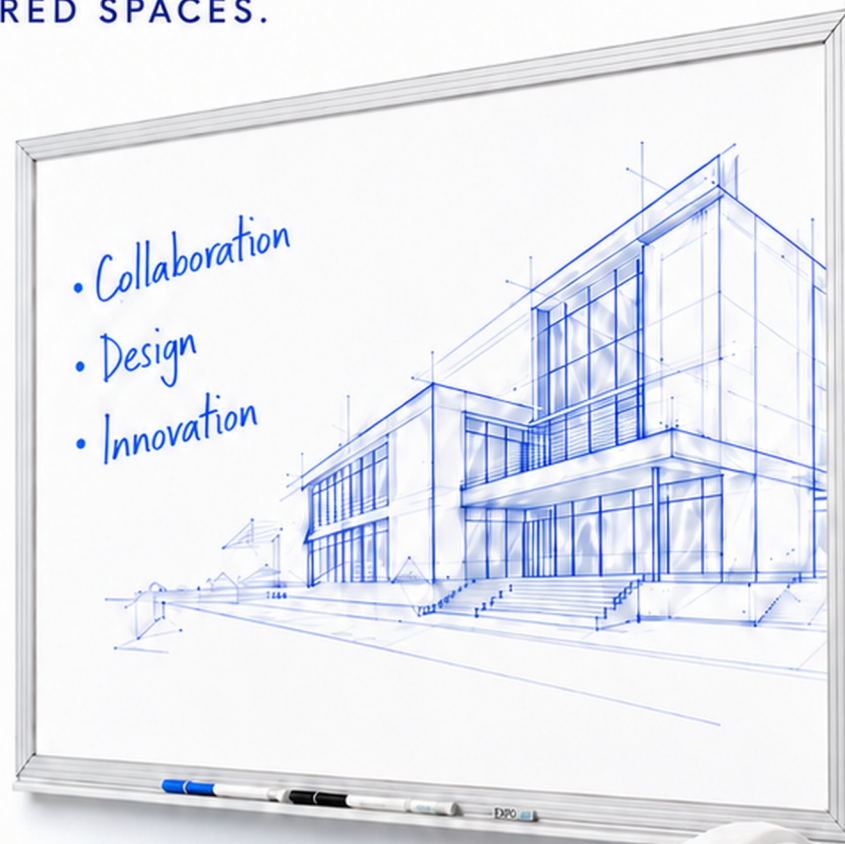

DESIGNED FOR PERFORMANCE. | BUILT FOR SPACES THAT INSPIRE.



## Lifetime Guarantee

### Whiteboards Guaranteed Not to Stain

#### *An EVERWhite Whiteboard Stays Clean and Bright for a Lifetime*

EVERWhite whiteboards, proudly **manufactured by EVERWhite** in the USA, are **guaranteed not to stain for a lifetime**.

We are able to offer this lifetime guarantee due to our proprietary, non-porous dry erase surface.

An EVERWhite whiteboard surface will always easily wipe clean and remain white. Even permanent marker ink can be removed from our boards, as the ink cannot penetrate the non-porous surface.

No special cleaners or tools are needed to maintain the surface. While the EVERWhite surface is hard and durable, sharp objects that could scratch the surface should not be used.

Because EVERWhite whiteboards remain white and stain-free, the total cost of ownership is lower than other brands, and maintenance is a breeze. It's simply the best whiteboard surface available.



## The EVERWhite Warranty

EVERWhite Corporation, dba EVERWhite ("Seller"), warrants EVERWhite® products to be free from factory defects in material and workmanship for a period of one year from date of purchase. Warranty covers replacement of defective product but does not include the cost of removal or reinstallation. To file a claim for factory defects in material or workmanship, you must contact an EVERWhite customer service representative within one year of purchase.

For EVERWhite resurfacing panels and dry erase whiteboards (including combination dry erase boards and graphic dry erase boards), EVERWhite further provides a warranty against ghosting and staining, under normal use, for the life of the building where originally installed. This limited warranty assumes normal use with suitable, dry erase markers and household non-abrasive glass cleaners. Any scratch or other alteration to the dry erase surface, whether intended or accidental, shall render this warranty null and void. Seller's sole obligation under this limited warranty would be a refund of the purchase price, subject to EVERWhite's Prorated Depreciation Schedule. Warranty covers replacement of defective product but does not include the cost of removal or reinstallation.

The warranty is only valid for the original purchasing entity. EVERWhite products are designed to be installation-ready, however, installation and the installation environment are out of EVERWhite's control and therefore installation is not warranted by EVERWhite in any circumstance.

To file a claim, contact an EVERWhite customer service representative at (800) 335-7319. **Warning:** Use of abrasive cleaners, substances or sharp instruments may scratch the surface.

**Due to the sale of EVERWhite by Glenroy Inc. in November 2020, any warranty claims for products purchased and shipped prior to November 2020 will be honored at the discretion of Glenroy, Inc. Please contact EVERWhite customer service for help initiating a claim.**



# Maintenance Instructions

everwhiteboards.com  
phone 800-335-7319  
sales@everwhiteboards.com

**At EVERWhite, our name is our promise. EVERWhite dry erase boards feature a unique surface that does not allow marker ink to penetrate, and under normal use and maintenance, we guarantee that your EVERWhite dry erase board will stay white for a lifetime.**



### Cleaning Your EVERWhite Dry Erase Board:

A protective layer is placed on each EVERWhite board to protect the surface during transit. After installation, this protective layer must be removed, and the board must be cleaned with window or glass cleaner BEFORE the first use.

Over time, dry erase markers may leave behind particles on whiteboards that resemble dust or residue. To keep your EVERWhite board looking new, simply clean the surface periodically with water or regular household glass cleaner. No expensive dry erase board cleaners are required.

We recommend using a microfiber cloth as an eraser, such as our EVERCloth, because microfiber cloths are superior for capturing and removing marker ink residue. Before using other types of whiteboard erasers, confirm that there are no sharp filaments or sharp edges that could scratch the board. You may contact one of our Customer Service Representatives at **800-335-7319** or request samples of the EVERWhite surface that may be used for testing erasers. EVERWhite cannot be held liable for damage caused by unsuitable erasers.

### Removing Permanent Marker Ink:

Permanent marker ink can be quickly and easily removed from the EVERWhite surface. Using a regular dry erase marker, simply write over the permanent marker. Then, erase as usual.

To remove permanent marker ink from a larger portion of the EVERWhite surface, please call our customer service department at **800-335-7319** to receive information on recommended cleaners. NEVER use a scouring pad or abrasive cleaner, as this may destroy the whiteboard surface.

### Removing Tape, Stickers, etc.:

To remove items such as tape or stickers from the EVERWhite surface, use an adhesive remover such as GooGone®. Never use anything abrasive or sharp tool to remove these items—not even your fingernails.

### Use of Magnets:

Do not slide magnets across the EVERWhite surface or use any magnets with sharp edges. Sliding magnets across the surface or using magnets with sharp edges may cause damage to the EVERWhite surface. If the EVERWhite surface is scratched, the lifetime stain-free guarantee is voided because scratching may compromise the stain resistance of the surface.

### Recommended Products for Cleaning Your EVERWhite Boards:

No expensive or harsh cleaners are necessary for cleaning your EVERWhite board. Water or household glass cleaner such as Windex® is recommended.

If you have questions about cleaners, you may call our customer service department at **800-335-7319** or email [sales@everwhiteboards.com](mailto:sales@everwhiteboards.com)

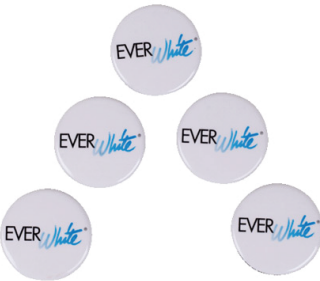



## TECHNICAL PERFORMANCE

Our specifically engineered dry erase composite surface provides excellent printability and erasability in an impervious formulation. EVERWhite offers the best quality features of scratch, chemical, stain, heat, and wear resistance and remains unsurpassed when compared and contrasted with our competition.

FEATURES	PROPERTY	RESULT
WRITEABILITY	Use of any dry erase, fluorescent, semi-permanent, and permanent markers and crayons will not damage the Everase surface.	Better than comparable products
ERASABILITY	Dry erasability using Boone 30 day test method	5 lbs/3 rubs or better with all tested dry erase markers*
	Gloss at 60 degrees using BYK Gardner / Micro-TRI-Gloss Test Method	100%
VISIBILITY	Excellent contrast compared to chalkboards. Allows for multi-color presentations	Excellent
PRINTABILITY	Excellent marker pen printability and erasability	Better than comparable products
	Non-ghosting, non-yellowing product	
	Both permanent and dry erase markers can be used for permanent and temporary information but then cleaned easily	
DURABILITY	Scratch resistance using Hoffman Scratch Test	700
	Hardness - Pencil using ASTM D3363-74	7H
WEARABILITY	Abrasion resistance using Taber Abrasion / 500 g - CS-10 Wheel	500 cycles
	Wear resistance using BYK Gardner Sled	5000 cycles
STAIN RESISTANCE	NEMA LD3-2000 3-4 Stain Resistance Report	Coffee, Tea, Mustard, Black permanent marker, #2 Pencil, Wax Crayon, Lipstick: 0 (No effect)
CHEMICAL RESISTANCE	ASTM D-1308 Method B-24 Report	Glass Cleaner - No stain Rubbing alcohol - No stain MEK (Methyl Ethyl Ketone) - No stain

These lab results are provided as a service only. All products are sold upon condition that the purchaser shall make their own tests and judgments. No warranty of merchantability or fitness for any purpose is implied by these test results, neither does this constitute the seller's product specifications. EVERWhite® is a Registered Trademark. \* Test Method and Results are available upon request.



SECTION 10100  
VISUAL DISPLAY BOARDS

Display hidden notes to specifier. (Don't know how? [Click Here](#))

PART 1 GENERAL

1.1 SECTION INCLUDES

- A. Visual Display Boards.
- B. Bulletin Boards.
- C. Display Board Accessories.

1.2 RELATED SECTIONS

- A. Section 06100 - Rough Carpentry: Wall Framing and Blocking.
- B. Section 05100 - Structural Metal Framing: Wall Framing and Blocking.
- C. Section 09200 - Plaster and Gypsum Board: Wall finishes prepared to receive boards.

1.3 REFERENCES

- A. ASTM E 84 - Standard Test Method for Surface Burning Characteristics for Building Materials.

1.4 SUBMITTALS

- A. A. Submit under provisions of Section 01300.
- B. Product Data: Manufacturer's data sheets on each product to be used, including:
  - 1. Preparation instructions and recommendations.
  - 2. Storage and handling requirements and recommendations.
  - 3. Installation methods.
- C. Shop Drawings: Submit manufacturer's standard drawings detailing plan and section views for each product specified.
- D. Selection Samples: For each finished product specified, complete sets of samples representing manufacturer's full range of available colors and patterns are available upon request.

1.5 QUALITY ASSURANCE

- A. Manufacturer Qualifications: All primary products specified in this section will be provided by a single manufacturer with a minimum of ten (10) years experience.
- B. Regulatory Requirements: Conform to applicable code for flame/smoke ratings in bulletin boards in accordance with ASTM E84.

## 1.6 DELIVERY, STORAGE, AND HANDLING

- A. After opening and inspecting boards for damage, return them to their original crates or cartons for storage and do not uncrate until boards are to be installed.
  - 1. When uncrated, do not allow boards to lean at an angle against a wall or other objects, or to lie on the floor for any length of time.
  - 2.
  - 3. Store boards in as close to a vertical position as possible.
- B. Storage and Protection: Store materials protected from exposure to harmful weather conditions and at temperature and humidity conditions recommended by manufacturer
- C. Store and dispose of hazardous materials, and materials used with hazardous materials, in accordance with requirements of local authorities having jurisdiction.

## 1.7 PROJECT CONDITIONS

- A. Maintain environmental conditions (temperature, humidity, and ventilation) within limits recommended by manufacturer for optimum results. Do not install products under environmental conditions outside manufacturer's absolute limits.
- B. EverWhite products are designed to be installation-ready, however, installation and the installation environment are out of EverWhite's control and therefore installation is not warranted by EverWhite in any circumstance.

## 1.8 WARRANTY

- A. The warranty is only valid for the original purchasing entity and covers replacement of defective product but does not include the cost of removal or reinstallation.
- B. Warranty for Laminated Face Sheet: Upon request, provide to owner or owner's representative an executed copy of the Manufacturer's standard warranty in which the manufacturer agrees to repair or replace laminated face sheets that fail in material or workmanship for a period of one year from the date of purchase. Seller's sole obligation under this limited warranty would be a refund of the purchase price, subject to EverWhite's Prorated Depreciation Schedule.
- C. Failures are limited to surfaces that exhibit ghosting or staining. All EverWhite dry erase surfaces are guaranteed against ghosting and staining for the lifetime of the building. Seller's sole obligation under this limited warranty would be a refund of the purchase price, subject to EverWhite's Prorated Depreciation Schedule.

## PART 2 PRODUCTS

### 2.1 MANUFACTURERS

- A. Acceptable Manufacturer: EverWhite, which is located at: 184 Railroad Drive, Warminster, PA, 18974 Toll Free Tel: 800-335-7319; Email: [sales@everwhiteboards.com](mailto:sales@everwhiteboards.com); Web: [www.everwhiteboards.com](http://www.everwhiteboards.com).
- B. Substitutions: Not permitted.
- C. Requests for substitutions will be considered in accordance with provisions of Section 01600.

### 2.2 DISPLAY BOARDS

- A. Magnetic Dry Erase Board: Balanced, high-pressure, factory-laminated dry erase board assembly of 3-ply construction consisting of backing sheet, core material, and a laminated 24-

gauge steel face sheet with durable gloss finish highly resistant to ghosting and staining.

1. Face Sheet: Laminated 24 gauge steel sheet.
2. Color: White.
3. Core Material: 1/2 inch (12mm) thick hexacomb material.
4. Backing Sheet: 0.003 inch (0.1mm) thick manufacturer's standard moisture barrier.
5. Thickness: Nominal 1/2 inch (13mm).
6. Size: 1 foot tall by 1 foot wide (304x304mm) board.
7. Size: 1-1/2 foot tall by 2 foot wide (457x609mm) board.
8. Size: 2 foot tall by 2 foot wide (609x609mm) board.
9. Size: 2 foot tall by 3 foot wide (609x914mm) board.
10. Size: 2 foot tall by 4 foot wide (609x1219mm) board.
11. Size: 3 foot tall by 4 foot wide (914x1219mm) board.
12. Size: 4 foot tall by 4 foot wide (1219x1219mm) board.
13. Size: 4 foot tall by 5 foot wide (1219x1560mm) board.
14. Size: 4 foot tall by 6 foot wide (1219x1829mm) board.
15. Size: 4 foot tall by 8 foot wide (1219x2438mm) board.
16. Size: 4 foot tall by 10 foot wide (1219x3048mm) board.
17. Size: 4 foot tall by 12 foot wide (1219x3658mm) board.
18. Size: 4 foot tall by 16 foot wide (1219x4877mm) board.
19. Size: 4 foot tall by 20 foot wide (1219x6096mm) board.
20. Size: 4 foot tall by 24 foot wide (1219x7315mm) board.
21. Size: \_\_\_ foot tall by \_\_\_ foot wide (\_\_\_\_\_ x \_\_\_\_\_mm) board.
22. Assembly: All boards are one piece up to 12 feet (3658mm) in length. When length exceeds 12 feet (3658mm), manufacturer's H-Channel will be provided. Assembly required at site.

B. Non-Magnetic Dry Erase Board: Balanced, high-pressure, factory-laminated dry erase board assembly of 3-ply construction consisting of backing sheet, core material, and a laminated hardboard face sheet with durable gloss finish highly resistant to ghosting and staining.

1. Face Sheet: Laminated 1/8 inch (3mm) thick hardboard.
2. Color: White.
3. Core Material: 3/8 inch (9.5mm) thick hexacomb material.
4. Backing Sheet: 0.003 inch (0.1mm) thick manufacturer's standard moisture barrier.
5. Thickness: Nominal 1/2 inch (13mm).
6. Size: 1 foot tall by 1 foot wide (304x304mm) board.
7. Size: 1-1/2 foot tall by 2 foot wide (457x609mm) board.
8. Size: 2 foot tall by 2 foot wide (609x609mm) board.
9. Size: 2 foot tall by 3 foot wide (609x914mm) board.
10. Size: 2 foot tall by 4 foot wide (609x1219mm) board.
11. Size: 3 foot tall by 4 foot wide (914x1219mm) board.
12. Size: 4 foot tall by 4 foot wide (1219x1219mm) board.
13. Size: 4 foot tall by 5 foot wide (1219x1560mm) board.
14. Size: 4 foot tall by 6 foot wide (1219x1829mm) board.
15. Size: 4 foot tall by 8 foot wide (1219x2438mm) board.
16. Size: 4 foot tall by 10 foot wide (1219x3048mm) board.
17. Size: 4 foot tall by 12 foot wide (1219x3658mm) board.
18. Size: 4 foot tall by 16 foot wide (1219x4877mm) board.
19. Size: 4 foot tall by 20 foot wide (1219x6096mm) board.
20. Size: 4 foot tall by 24 foot wide (1219x7315mm) board.
21. Size: \_\_\_ foot tall by \_\_\_ foot wide (\_\_\_\_\_ x \_\_\_\_\_mm) board.
22. Assembly: All boards are one piece up to 12 feet (3658mm) in length. When length exceeds 12 feet (3658mm), manufacturer's H-Channel will be provided. Assembly required at site.

C. Laminated Steel Resurfacing Panel: A laminated steel face sheet with a durable gloss finish highly resistant to ghosting and staining.

1. Face Sheet: Laminated 24 gauge steel sheet.
2. Color: White.
3. Mounting Adhesive: Manufacturer's standard pre-applied pressure sensitive

10100-3

Revised 3.30.2022

Rev Level B

adhesive.

4. Size: 1 foot tall by 1 foot wide (304x304mm) board.
5. Size: 1-1/2 foot tall by 2 foot wide (457x609mm) board.
6. Size: 2 foot tall by 2 foot wide (609x609mm) board.
7. Size: 2 foot tall by 3 foot wide (609x914mm) board.
8. Size: 2 foot tall by 4 foot wide (609x1219mm) board.
9. Size: 3 foot tall by 4 foot wide (914x1219mm) board.
10. Size: 4 foot tall by 4 foot wide (1219x1219mm) board.
11. Size: 4 foot tall by 5 foot wide (1219x1560mm) board.
12. Size: 4 foot tall by 6 foot wide (1219x1829mm) board.
13. Size: 4 foot tall by 8 foot wide (1219x2438mm) board.
14. Size: 4 foot tall by 10 foot wide (1219x3048mm) board.
15. Size: 4 foot tall by 12 foot wide (1219x3658mm) board.
16. Size: 4 foot tall by 16 foot wide (1219x4877mm) board.
17. Size: 4 foot tall by 20 foot wide (1219x6096mm) board.
18. Size: 4 foot tall by 24 foot wide (1219x7315mm) board.
19. Size: \_\_\_ foot tall by \_\_\_ foot wide (\_\_\_\_\_ x \_\_\_\_\_ mm) board.
20. Assembly: All boards are one piece up to 12 feet (3658mm) in length. When length exceeds 12 feet (3658mm), manufacturer's seam strip will be provided. Installation required at site.

D. ULTIMatte Magnetic Dry Erase Board: Balanced, high-pressure, factory-laminated dry erase board assembly of 3-ply construction consisting of backing sheet, core material, and a laminated 24-gauge steel face sheet with durable matte finish highly resistant to ghosting and staining. Can be used as a projection surface as well as a whiteboard.

1. Face Sheet: Laminated 24 gauge steel sheet.
2. Color: White.
3. Core Material: 1/2 inch (12mm) thick hexacomb material.
4. Backing Sheet: 0.003 inch (0.1mm) thick manufacturer's standard moisture barrier.
5. Thickness: Nominal 1/2 inch (13mm).
6. Size: 1 foot tall by 1 foot wide (304x304mm) board.
7. Size: 1-1/2 foot tall by 2 foot wide (457x609mm) board.
8. Size: 2 foot tall by 2 foot wide (609x609mm) board.
9. Size: 2 foot tall by 3 foot wide (609x914mm) board.
10. Size: 2 foot tall by 4 foot wide (609x1219mm) board.
11. Size: 3 foot tall by 4 foot wide (914x1219mm) board.
12. Size: 4 foot tall by 4 foot wide (1219x1219mm) board.
13. Size: 4 foot tall by 5 foot wide (1219x1560mm) board.
14. Size: 4 foot tall by 6 foot wide (1219x1829mm) board.
15. Size: 4 foot tall by 8 foot wide (1219x2438mm) board.
16. Size: 4 foot tall by 10 foot wide (1219x3048mm) board.
17. Size: 4 foot tall by 12 foot wide (1219x3658mm) board.
18. Size: 4 foot tall by 16 foot wide (1219x4877mm) board.
19. Size: 4 foot tall by 20 foot wide (1219x6096mm) board.
20. Size: 4 foot tall by 24 foot wide (1219x7315mm) board.
21. Size: 5 foot tall by 6 foot wide (1524x1829mm) board.
22. Size: 5 foot tall by 8 foot wide (1524x2438mm) board.
23. Size: 5 foot tall by 10 foot wide (1524x3048mm) board.
24. Size: 5 foot tall by 12 foot wide (1524x3658mm) board.
25. Size: \_\_\_ foot tall by \_\_\_ foot wide (\_\_\_\_\_ x \_\_\_\_\_ mm) board.
26. Assembly: All boards are one piece up to 12 feet (3658mm) in length. When length exceeds 12 feet (3658mm), manufacturer's H-Channel will be provided. Assembly required at site.

E. ULTIMatte Laminated Steel Resurfacing Panel: A laminated steel face sheet with a durable matte finish highly resistant to ghosting and staining. Can be used as a projection surface as well as a whiteboard.

1. Face Sheet: Laminated 24 gauge steel sheet.
2. Color: White.
3. Mounting Adhesive: Manufacturer's standard pre-applied pressure sensitive adhesive.
4. Size: 1 foot tall by 1 foot wide (304x304mm) board.
5. Size: 1-1/2 foot tall by 2 foot wide (457x609mm) board.
6. Size: 2 foot tall by 2 foot wide (609x609mm) board.
7. Size: 2 foot tall by 3 foot wide (609x914mm) board.
8. Size: 2 foot tall by 4 foot wide (609x1219mm) board.
9. Size: 3 foot tall by 4 foot wide (914x1219mm) board.
10. Size: 4 foot tall by 4 foot wide (1219x1219mm) board.
11. Size: 4 foot tall by 5 foot wide (1219x1560mm) board.
12. Size: 4 foot tall by 6 foot wide (1219x1829mm) board.
13. Size: 4 foot tall by 8 foot wide (1219x2438mm) board.
14. Size: 4 foot tall by 10 foot wide (1219x3048mm) board.
15. Size: 4 foot tall by 12 foot wide (1219x3658mm) board.
16. Size: 4 foot tall by 16 foot wide (1219x4877mm) board.
17. Size: 4 foot tall by 20 foot wide (1219x6096mm) board.
18. Size: 4 foot tall by 24 foot wide (1219x7315mm) board.
19. Size: 5 foot tall by 6 foot wide (1524x1829mm) board.
20. Size: 5 foot tall by 8 foot wide (1524x2438mm) board.
21. Size: 5 foot tall by 10 foot wide (1524x3048mm) board.
22. Size: 5 foot tall by 12 foot wide (1524x3658mm) board.
23. Size: \_\_\_ foot tall by \_\_\_ foot wide (\_\_\_\_\_ x \_\_\_\_\_mm) board.
24. Assembly: All boards are one piece up to 12 feet (3658mm) in length. When length exceeds 12 feet (3658mm), manufacturer's seam strip will be provided. Installation required at site.

F. Cork Bulletin Board: Self healing tack assembly composed of natural cork sheet factory laminated to a hardboard backing.

1. Face Sheet: Laminated 1/4 inch (6mm) thick natural cork sheet.
2. Backing Sheet: 3/8 inch (10mm) thick hardboard.
3. Size: 1 foot tall by 1 foot wide (304x304mm) board.
4. Size: 1-1/2 foot tall by 2 foot wide (457x609mm) board.
5. Size: 2 foot tall by 2 foot wide (609x609mm) board.
6. Size: 2 foot tall by 3 foot wide (609x914mm) board.
7. Size: 2 foot tall by 4 foot wide (609x1219mm) board.
8. Size: 3 foot tall by 4 foot wide (914x1219mm) board.
9. Size: 4 foot tall by 4 foot wide (1219x1219mm) board.
10. Size: 4 foot tall by 5 foot wide (1219x1560mm) board.
11. Size: 4 foot tall by 6 foot wide (1219x1829mm) board.
12. Size: 4 foot tall by 8 foot wide (1219x2438mm) board.
13. Size: 4 foot tall by 10 foot wide (1219x3048mm) board.
14. Size: 4 foot tall by 12 foot wide (1219x3658mm) board.
15. Size: 4 foot tall by 16 foot wide (1219x4877mm) board.
16. Size: 4 foot tall by 20 foot wide (1219x6096mm) board.
17. Size: 4 foot tall by 24 foot wide (1219x7315mm) board.
18. Size: \_\_\_ foot tall by \_\_\_ foot wide (\_\_\_\_\_ x \_\_\_\_\_mm) board.

## 2.3 BOARD CONFIGURATION

- A. Combination Board Style A: Two Panels - Vertical H-Channel.
  1. Size: 1 foot tall by 1 foot wide (304x304mm) board.
  2. Size: 1-1/2 foot tall by 2 foot wide (457x609mm) board.
  3. Size: 2 foot tall by 2 foot wide (609x609mm) board.
  4. Size: 2 foot tall by 3 foot wide (609x914mm) board.
  5. Size: 2 foot tall by 4 foot wide (609x1219mm) board.
  6. Size: 3 foot tall by 4 foot wide (914x1219mm) board.

10100-5

Revised 3.30.2022

Rev Level B

7. Size: 4 foot tall by 4 foot wide (1219x1219mm) board.
8. Size: 4 foot tall by 5 foot wide (1219x1560mm) board.
9. Size: 4 foot tall by 6 foot wide (1219x1829mm) board.
10. Size: 4 foot tall by 8 foot wide (1219x2438mm) board.
11. Size: 4 foot tall by 10 foot wide (1219x3048mm) board.
12. Size: 4 foot tall by 12 foot wide (1219x3658mm) board.
13. Size: 4 foot tall by 16 foot wide (1219x4877mm) board.
14. Size: 4 foot tall by 20 foot wide (1219x6096mm) board.
15. Size: 4 foot tall by 24 foot wide (1219x7315mm) board.

16. Placement:

- a. Left Side: Cork Bulletin Board.
- b. Left Side: Dry Erase Board.
- c. Right Side: Cork Bulletin Board.
- d. Right Side: Dry Erase Board.

B. Combination Board Style B: Three Panels - Dual Vertical H-Channels.

1. Size: 3 foot tall by 3 foot wide (914x914mm) board.
2. Size: 4 foot tall by 4 foot wide (1219x1219mm) board.
3. Size: 4 foot tall by 6 foot wide (1219x1829mm) board
4. Size: 4 foot tall by 8 foot wide (1219x2438mm) board.
5. Size: 4 foot tall by 10 foot wide (1219x3048mm) board.
6. Size: 4 foot tall by 12 foot wide (1219x3658mm) board.
7. Size: 4 foot tall by 16 foot wide (1219x4877mm) board.
8. Size: 4 foot tall by 20 foot wide (1219x6096mm) board.
9. Size: 4 foot tall by 24 foot wide (1219x7315mm) board.

10. Placement:

- a. Left Side: Cork Bulletin Board.
- b. Center: Dry Erase Board.
- c. Right Side: Cork Bulletin Board.

C. Combination Board Style C: 2 Panels – H-Channel, Overhead Bulletin Board.

1. Size: 2 foot tall by 2 foot wide (609x609mm) board.
2. Size: 3 foot tall by 3 foot wide (914x914mm) board.
3. Size: 4 foot tall by 4 foot wide (1219x1219mm) board.
4. Size: 4 foot tall by 6 foot wide (1219x1829mm) board
5. Size: 4 foot tall by 8 foot wide (1219x2438mm) board.
6. Size: 4 foot tall by 10 foot wide (1219x3048mm) board.
7. Size: 4 foot tall by 12 foot wide (1219x3658mm) board.
8. Size: 4 foot tall by 16 foot wide (1219x4877mm) board.
9. Size: 4 foot tall by 20 foot wide (1219x6096mm) board.
10. Size: 4 foot tall by 24 foot wide (1219x7315mm) board.

11. Size: \_\_\_ foot tall by \_\_\_ foot wide (\_\_\_\_\_ x \_\_\_\_\_mm) board.

12. Placement:

- a. Upper: Cork Bulletin Board.
- b. Lower: Dry Erase Board.
- c. H-Channel

D. Combination Board Style D: 4 Panels - Dual Vertical H-Channels, Horizontal H-Channel, and Overhead Bulletin Board.

1. Size: 4 foot tall by 4 foot wide (1219x1219mm) board.
2. Size: 4 foot tall by 6 foot wide (1219x1829mm) board
3. Size: 4 foot tall by 8 foot wide (1219x2438mm) board.
4. Size: 4 foot tall by 10 foot wide (1219x3048mm) board.
5. Size: 4 foot tall by 12 foot wide (1219x3658mm) board.
6. Size: 4 foot tall by 16 foot wide (1219x4877mm) board.
7. Size: 4 foot tall by 20 foot wide (1219x6096mm) board.

10100-6

Revised 3.30.2022

Rev Level B

8. Size: 4 foot tall by 24 foot wide (1219x7315mm) board.
9. Size: \_\_\_ foot tall by \_\_\_ foot wide (\_\_\_\_\_ x \_\_\_\_\_mm) board.
10. Placement:
  - a. Upper: Cork Bulletin Board.
  - b. Left Side: Cork Bulletin Board.
  - c. Center: Dry Erase Board.
  - d. Right Side: Cork Bulletin Board.
  - e. H-Channels.

E. Standard Graphic Boards: Graphics permanently laminated into dry erase board.

1. Graphic: Penmanship lines.
2. Graphic: Music staff lines.
3. Graphic: 1 inch (25mm) square grid lines.
4. Graphic: EZ Grid, Grid 1"
5. Graphic: EZ Grid, Grid 2"
6. Graphic: EZ Grid, Dot 1"
7. Graphic: EZ Grid, Dot 2"
8. Graphic: EZ Grid, ISO 1"
9. Graphic: EZ Grid, ISO 2"
10. Graphic: Standard Sport, Basketball
11. Graphic: Standard Sport, Hockey
12. Graphic: Standard Sport, Football
13. Graphic: Standard Sport, Soccer
14. Graphic: Standard Sport, Volleyball
15. Graphic: Calendars, 1, 2, 3, 4, 6 & 12 months and 1 month plus
16. Placement: Covering entire dry erase board.
17. Size: 1 foot tall by 1 foot wide (304x304mm) board.
18. Size: 1-1/2 foot tall by 2 foot wide (457x609mm) board.
19. Size: 2 foot tall by 2 foot wide (609x609mm) board.
20. Size: 2 foot tall by 3 foot wide (609x914mm) board.
21. Size: 2 foot tall by 4 foot wide (609x1219mm) board.
22. Size: 3 foot tall by 4 foot wide (914x1219mm) board.
23. Size: 4 foot tall by 4 foot wide (1219x1219mm) board.
24. Size: 4 foot tall by 5 foot wide (1219x1560mm) board.
25. Size: 4 foot tall by 6 foot wide (1219x1829mm) board.
26. Size: 4 foot tall by 8 foot wide (1219x2438mm) board.
27. Size: 4 foot tall by 10 foot wide (1219x3048mm) board.
28. Size: 4 foot tall by 12 foot wide (1219x3658mm) board.

F. Graphic Combination Boards: 4 foot by 4 foot (1219mm x 1219mm) graphic permanently laminated onto one side of the dry erase board. Remaining surface of the board remains plain.

1. Graphic: Penmanship lines.
2. Graphic: Music staff lines.
3. Graphic: 1 inch (25mm) square grid lines.
4. Graphic: EZ Grid, Grid 1"
5. Graphic: EZ Grid, Grid 2"
6. Graphic: EZ Grid, Dot 1"
7. Graphic: EZ Grid, Dot 2"
8. Graphic: EZ Grid, ISO 1"
9. Graphic: EZ Grid, ISO 2"
10. Graphic: Standard Sport, Basketball
11. Graphic: Standard Sport, Hockey
12. Graphic: Standard Sport, Football
13. Graphic: Standard Sport, Soccer
14. Graphic: Standard Sport, Volleyball
15. Graphic: Calendars, 1, 2, 3, 4, 6 & 12 months and 1 month plus
16. Graphic: \_\_\_\_\_
17. Size Restrictions: All graphics can be ordered in all available sizes.

- 18. Size: 4 foot tall by 4 foot wide (1219x1219mm) board.
- 19. Size: 4 foot tall by 5 foot wide (1219x1560mm) board.
- 20. Size: 4 foot tall by 6 foot wide (1219x1829mm) board.
- 21. Size: 4 foot tall by 8 foot wide (1219x2438mm) board.
- 22. Size: 4 foot tall by 10 foot wide (1219x3048mm) board.
- 23. Size: 4 foot tall by 12 foot wide (1219x3658mm) board.
- 24. Size: 4 foot tall by 16 foot wide (1219x4877mm) board.
- 25. Size: \_\_\_ foot tall by \_\_\_ foot wide (\_\_\_\_\_ x \_\_\_\_\_ mm) board.
- 26. Assembly: All boards are one piece up to 12 feet (3658mm) in length. When length exceeds 12 feet (3658mm), manufacturer's H-Channel will be provided. Assembly required at site.

#### 2.4 FRAMING

##### A. Aluminum Frame and Marker Tray:

- 1. Thickness: .719 inch (18mm) thick, extruded aluminum frame.
- 2. Width: Narrow - 5/8 inch (15mm).
- 3. Width: Wide – 1 1/8 inch (29mm).
- 4. Marker Tray: 2 5/8 inch (67mm) Continuous solid extruded aluminum tray with 3 channels and protective plastic end caps.
- 5. Finish: Satin Anodized clear finish.
- 6. End Cap Color: Silver.

##### B. Wood Frame and Marker Tray:

- 1. Thickness: 0.875 inch (22mm) thick, solid wood frame.
- 2. Width: Narrow – 1 1/4 inch (32mm).
- 3. Width: Wide – 1 7/8 inch (48mm).
- 4. Marker Tray: 2 1/4 inch (64mm) deep single channel tray.
- 5. Wood Type: Natural Oak.
- 6. Wood Type: Maple.
- 7. Wood Type: Maple with Mahogany Stain.
- 8. Wood Type: Maple with Cherry Stain.
- 9. Wood Type: Maple with Black Paint.

#### 2.5 ACCESSORIES

##### A. Map Rail: Standard 1 inch (25mm) map rail with cork insert.

- 1. Map Hooks and Clips: Extruded Aluminum.
- 2. Flag Holder: Extruded Aluminum.
- 3. Map Winders: Extruded Aluminum.

##### B. Markers and Cleaning Cloths:

- 1. Dry Erase Marker Set including red, blue, green and black.
- 2. EverCloth - Reusable dry erase marking board cleaning cloth.

### PART 3 EXECUTION

#### 3.1 EXAMINATION AND PREPARATION

- A. Do not begin installation until substrates have been properly prepared.
- B. If substrate preparation is the responsibility of another installer, notify Architect of unsatisfactory preparation before proceeding.
- C. Clean surfaces thoroughly after installation with water or glass cleaner.

#### 3.2 INSTALLATION

- A. Install in accordance with manufacturer's instructions.
- B. Install all units in locations shown on plans, at mounting heights specified on the Contract Drawings. Keep perimeter lines straight, plumb and level.

C. EVERWhite products are designed to be installation-ready, however, installation and the installation environment are out of EVERWhite's control and therefore installation is not warranted by EWhite in any circumstance.

### 3.3 CLEANING AND PROTECTION

- A. Clean display boards prior to project closeout.
- B. Protect installed products until completion of project.
- C. Repair or replace damaged products before Substantial Completion.

END OF SECTION

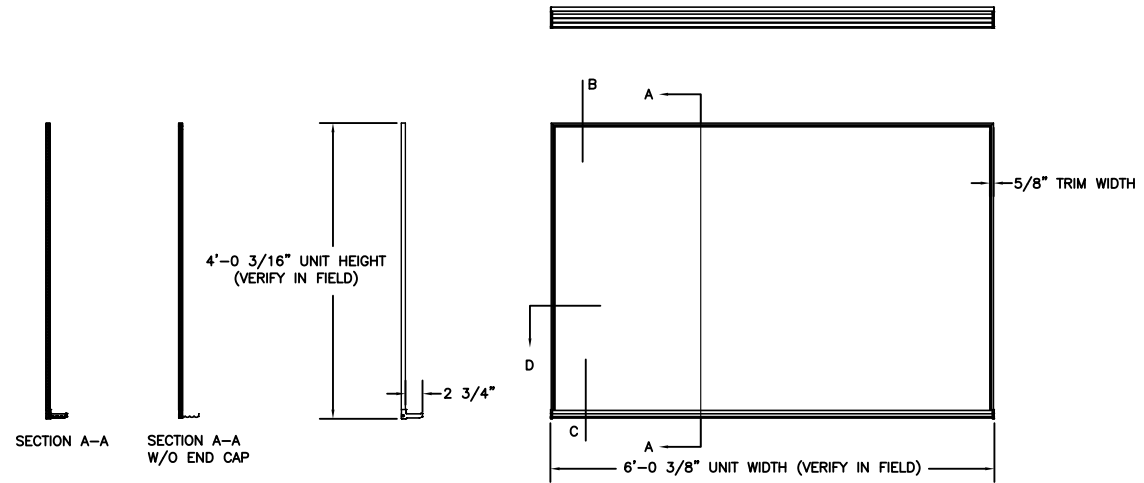
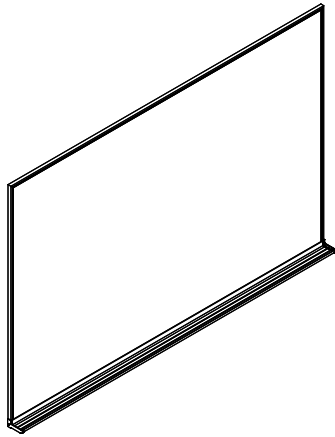

NOTE: RECOMMENDED MARKERBOARD MOUNTING HEIGHTS

- A) 2'4" FROM FLOOR FOR K-4th GRADE\*
- B) 2'8" FROM FLOOR FOR 5th & 6th GRADE\*
- C) 2'10" FROM FLOOR FOR 7th & 8th GRADE\*
- D) 3'0" FROM FLOOR FOR HIGH SCHOOL\*

\*(UNLESS OTHERWISE SPECIFIED BY ARCHITECT)

MARKERBOARD  
ELEVATION

$3/8" = 1'-0"$

ALUMINUM FRAMED BOARD SIZES  
FOR BOTH WIDE (1 1/8") & NARROW (3/8") FRAME STYLE

SIZE BOARD MAKE-UP

- 1' x 1' CONSISTS OF ONE 1' BOARD
- 1.5' x 2' CONSISTS OF ONE 2' BOARD
- 2' x 2' CONSISTS OF ONE 2' BOARD
- 2' x 3' CONSISTS OF ONE 3' BOARD
- 2' x 4' CONSISTS OF ONE 4' BOARD
- 3' x 4' CONSISTS OF ONE 4' BOARD
- 4' x 4' CONSISTS OF ONE 4' BOARD
- 4' x 5' CONSISTS OF ONE 5' BOARD
- 4' x 6' CONSISTS OF ONE 6' BOARD
- 4' x 8' CONSISTS OF ONE 8' BOARD
- 4' x 10' CONSISTS OF ONE 10' BOARD
- 4' x 12' CONSISTS OF ONE 12' BOARD
- 4' x 16' CONSISTS OF TWO 8' BOARDS WITH H-CHANNEL
- 4' x 20' CONSISTS OF TWO 10' BOARDS WITH H-CHANNEL
- 4' x 24' CONSISTS OF TWO 12' BOARDS WITH H-CHANNEL

IMPORTANT NOTICE

FIELD VERIFY ALL DIMENSIONS AND  
LOCATIONS PRIOR TO MANUFACTURING

BOARD CONSTRUCTION TYPE:

- MAGNETIC
- NON-MAGNETIC
- CORK (TRAY NOT INCLUDED)

QTY	SIZE	TYPE	LOCATION	ADDITIONAL COMMENTS

BOARD SCHEDULE



184 RAILROAD DRIVE  
WARMINSTER, PA 18974  
PH (800) 335-7319  
FX (215) 323-4135

CUSTOMER SERVICE AND  
SUPPORT (800) 335-7319  
WWW.EVERWHITEBOARDS.COM  
MADE IN THE USA



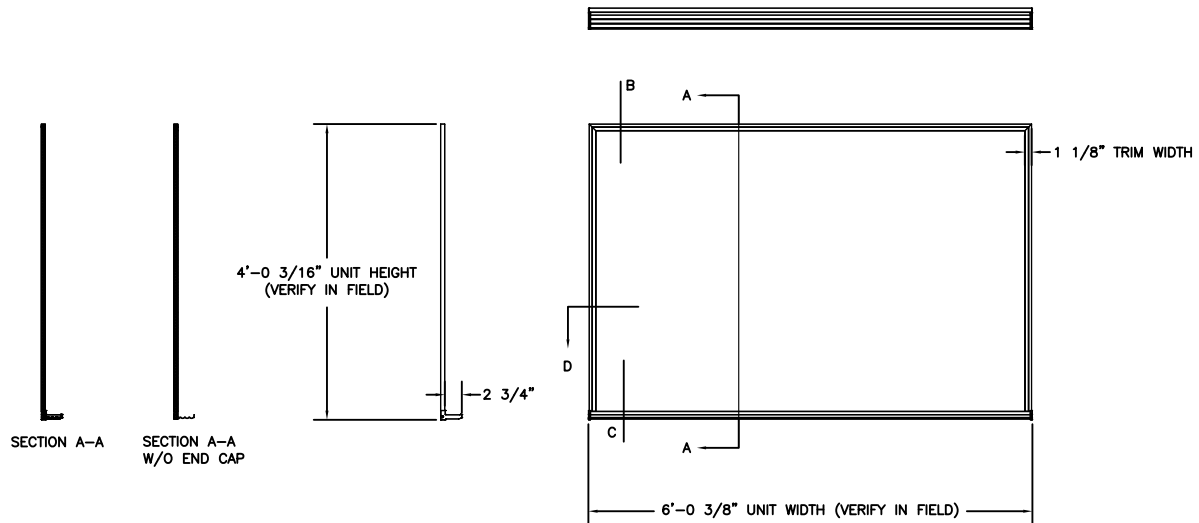
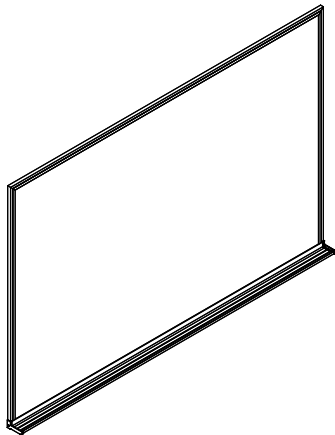

NOTE: RECOMMENDED MARKERBOARD MOUNTING HEIGHTS

- A) 2'4" FROM FLOOR FOR K-4th GRADE\*
- B) 2'8" FROM FLOOR FOR 5th & 6th GRADE\*
- C) 2'10" FROM FLOOR FOR 7th & 8th GRADE\*
- D) 3'0" FROM FLOOR FOR HIGH SCHOOL\*

\*(UNLESS OTHERWISE SPECIFIED BY ARCHITECT)

MARKERBOARD  
ELEVATION

3/8" = 1'-0"

ALUMINUM FRAMED BOARD SIZES  
FOR BOTH WIDE (1 1/8") & NARROW (3/8") FRAME STYLE

SIZE	BOARD MAKE-UP
1' x 1'	CONSISTS OF ONE 1' BOARD
1.5' x 2'	CONSISTS OF ONE 2' BOARD
2' x 2'	CONSISTS OF ONE 2' BOARD
2' x 3'	CONSISTS OF ONE 3' BOARD
2' x 4'	CONSISTS OF ONE 4' BOARD
3' x 4'	CONSISTS OF ONE 4' BOARD
4' x 4'	CONSISTS OF ONE 4' BOARD
4' x 5'	CONSISTS OF ONE 5' BOARD
4' x 6'	CONSISTS OF ONE 6' BOARD
4' x 8'	CONSISTS OF ONE 8' BOARD
4' x 10'	CONSISTS OF ONE 10' BOARD
4' x 12'	CONSISTS OF ONE 12' BOARD
4' x 16'	CONSISTS OF TWO 8' BOARDS WITH H-CHANNEL
4' x 20'	CONSISTS OF TWO 10' BOARDS WITH H-CHANNEL
4' x 24'	CONSISTS OF TWO 12' BOARDS WITH H-CHANNEL

IMPORTANT NOTICE

FIELD VERIFY ALL DIMENSIONS AND  
LOCATIONS PRIOR TO MANUFACTURING

BOARD CONSTRUCTION TYPE:

- MAGNETIC
- NON-MAGNETIC
- CORK (TRAY NOT INCLUDED)

QTY	SIZE	TYPE	LOCATION	ADDITIONAL COMMENTS

BOARD SCHEDULE



184 RAILROAD DRIVE  
WARMINSTER, PA 18974  
PH (800) 335-7319  
FX (215) 323-4135

CUSTOMER SERVICE AND  
SUPPORT (800) 335-7319  
WWW.EVERWHITEBOARDS.COM  
MADE IN THE USA



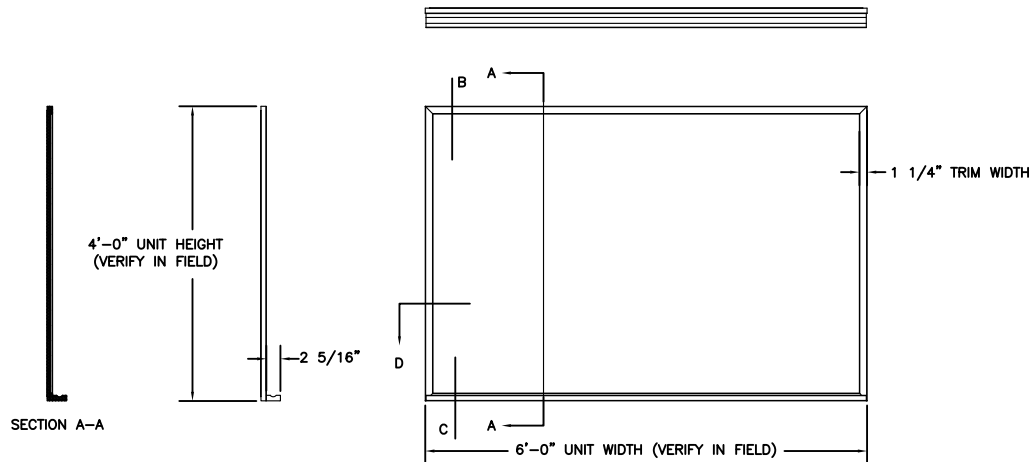
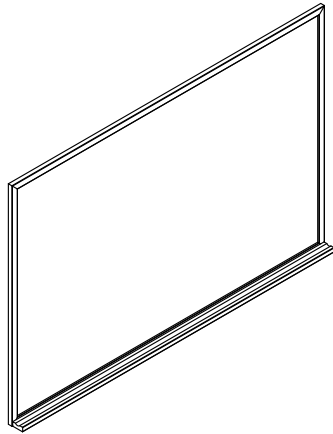

NOTE: RECOMMENDED MARKERBOARD MOUNTING HEIGHTS  
 1) 2'4" FROM FLOOR FOR K-4th GRADE\*  
 2) 2'8" FROM FLOOR FOR 5th & 6th GRADE\*  
 3) 2'10" FROM FLOOR FOR 7th & 8th GRADE\*  
 4) 3'0" FROM FLOOR FOR HIGH SCHOOL\*  
 \*(UNLESS OTHERWISE SPECIFIED BY ARCHITECT)

MARKERBOARD  
 ELEVATION  
 $\frac{3}{8}'' = 1'-0''$

BOARD CONSTRUCTION TYPE:  
 MAGNETIC  
 NON-MAGNETIC  
 CORK (TRAY NOT INCLUDED)

WOOD FRAMED BOARD SIZES  
 FOR NARROW (1 1/4") FRAME STYLE

SIZE	BOARD MAKE-UP
1.5' x 2'	CONSISTS OF ONE 2' BOARD
2' x 2'	CONSISTS OF ONE 2' BOARD
2' x 3'	CONSISTS OF ONE 3' BOARD
2' x 4'	CONSISTS OF ONE 4' BOARD
3' x 4'	CONSISTS OF ONE 4' BOARD
4' x 4'	CONSISTS OF ONE 4' BOARD
4' x 6'	CONSISTS OF ONE 6' BOARD

IMPORTANT NOTICE  
 FIELD VERIFY ALL DIMENSIONS AND  
 LOCATIONS PRIOR TO MANUFACTURING

QTY	SIZE	TYPE	LOCATION	ADDITIONAL COMMENTS

BOARD SCHEDULE



184 RAILROAD DRIVE  
 WARMINSTER, PA 18974  
 PH (800) 335-7319  
 FX (215) 323-4135

CUSTOMER SERVICE AND  
 SUPPORT (800) 335-7319  
 WWW.EVERWHITEBOARDS.COM  
 MADE IN THE USA















# EVERWhite Whiteboard Quick Install

**\* PLEASE FOLLOW INSTRUCTIONS CAREFULLY TO ENSURE A GOOD INSTALLATION\***

**Failure to follow directions may VOID All Warranties.**

## Proper Storing Instructions (Pre-Installation)

Some minor dimensional changes such as bowing may occur under certain climate conditions. Whiteboard bowing is related to the conditions of the environment and the wall. Bowing is subjective to what is acceptable by the end user; therefore, we cannot offer absolute guarantees for bowing. There are installer variables beyond our control that can affect final board performance — such as wall flatness, paint type, surface debris, temperature, and storage conditions.

- Avoid installation on damp surfaces or during humid weather.
- Our standard whiteboard is not recommended for highly humid areas. Contact customer service for alternate product construction.
- We recommend storing whiteboards in their original crates until installation. Ideal storage temperature is between 32° F and 150° F.
- DO NOT lean boards at an angle against a wall; they should remain flat until they are ready for installation.



### Make a Line for the Bottom of the Whiteboard at One of These Heights:

- High schools, colleges and universities, offices – 3'
- 7th and 8th grades - 2' 10"
- 5th and 6th grades - 2' 8"
- K through 4th grade - 2' 4"

Using a hand or laser device, make sure the line is level.

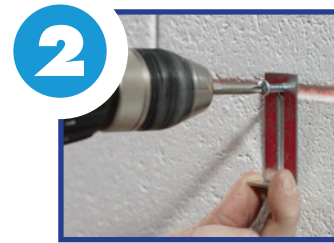

### BOTTOM CLIPS

#### Mark and Drill Two Holes for Each Bottom Support Clip

- Mark and drill the first hole along the level line.
- Hold a clip against the wall with the bottom of the clip slot at the drilled hole.
- Mark and drill a hole at the top of the clip slot.

#### Install Bottom Clips

- Tap in anchors, screw in mounting clips so the extending portion of the clip is along the level line.



### TOP CLIPS

#### Determine Location for Top Clips

- Rest whiteboard on previously secured bottom clips and mark the wall along the top of the board; remove the board.

#### Install Top Clips

- Mark and drill holes one inch below the top line, tap in anchors and screw in clips with the top of the clip a bit above the line. *(Once the board is in place, those clips will be tapped down to the top of the frame and then secured to the frame.)*

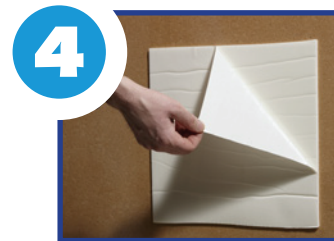

### INSTALL THE WHITEBOARD

**IMPORTANT!** Make sure the wall in the installation area is free of dust and debris and is clean and dry. This is critical for proper adhesion!

- Remove the liner from the adhesive strips on the back of the whiteboard.
- Lift the board onto the lower mounting clips.
- Firmly press the top, center and bottom of the board along the entire length so the adhesive adheres to the wall. A strong bond to the wall is important to reduce the severity/chances of bowing. This will hold the board in place while you secure the mounting clips to the frame.
- If your board has a map rail, attach it now.
- Tap down the top clips to touch the top of the frame.
- Secure the top and bottom of the frame to the mounting clips with self-tapping screws for aluminum frames or wood screws for wood frames.
- Once the board is secured, peel off the protective layer from the whiteboard surface. **The board must be cleaned with a glass cleaner BEFORE the first use!**

Recommended Number of Wall Clips		
Board Size	Top	Bottom
4x4 or smaller	2	2
4x6	3	3
4x8	4	4
4x10	5	5
4x12	6	6
4x16	8	8



See the maintenance instructions sheet under resources on our website [www.everwhiteboards.com](http://www.everwhiteboards.com)



## EVERWhite Resurfacing Quick Install

### RECOMMENDED TOOLS & SUPPLIES

- Acetone
- Rags
- Glass Cleaner
- Pen or Pencil
- Razor Scrapers
- Rubber Mallet
- Steel Shims

### BEFORE YOU BEGIN!

- EVERWhite panels are intended to cover chalkboards and whiteboards. Resurfacing panels are not suitable for other surfaces, such as vinyl surfaces.
- Do not apply resurfacing panels to unstable surfaces, as the panel might lose adhesion.
- If you are unsure about adhesion to your existing surface, call us at (800) 335-7319.
- Work gloves are recommended, as panel edges might be sharp.
- Remove finger jewelry to prevent accidental scratches of the new panel.
- An installation team of two to four people is recommended.
- Open the resurfacing panel in a hallway, so the packaging materials are not in the way.
- The top of the new panel is indicated by an EVERWhite logo.

1



### PREPARATION

1. Clean the existing surface with water, paying close attention to the corners.
  - a) Do not use any soap or oil-based cleaners!
2. Remove any tape or adhesive with a razor scraper, or Goo Gone and a scraper.
3. Clean the existing surface with acetone.
4. Allow the surface to fully dry before proceeding with installation.

2



### TEST THE FIT

Once the existing surface is prepared, dry-fitting is highly recommended.

1. Lift the panel toward the existing surface, with the lower edge of the panel resting on the existing chalk or marker tray.
2. If there is a gap behind the tray, fill it with steel shims.
3. If the fit around the frame is tight, use a rubber mallet to nudge the frame outward.
4. If mounting two or more panels next to each other, mark where one panel ends.
  - a) Leave no more than a 1/4-inch gap between the panels; a seam strip will cover the gap.

3



### INSTALLATION

Hold the panel upright, with the bottom edge resting on the floor. Remove the liner from the adhesive backing.

Lift the panel to the existing board, and, with the new surface leaning away, set the bottom edge of the panel on the existing tray.

4



# EVERWhite Resurfacing Quick Install



5 Slightly bend the resurfacing panel in an arc away from the existing surface. The bottom edge of the panel should be the only area contacting the old surface.



6 Make sure the bottom corners of the panel are aligned within the existing board frame. Then press the corners of the resurfacing panel against the old surface.



7 Run your hands in an upward vertical motion to ensure the bottom area is thoroughly adhered without air bubbles.



8 Relax the arc of the new panel, continually running your hands in an upward vertical motion to adhere the middle area of the panel.



9 Finally, push the panel against the upper corners of the old board.



10 Run your hands across the old board to ensure removal of all air bubbles.



11 Peel off the protective layer from the new panel's surface. **The board must be cleaned with a glass cleaner BEFORE the first use!**

## FINISHING TIPS

- For extra wide boards, apply the seam strip over the vertical gap between the panels.
- Clean the new surface with a common glass cleaner and a soft cloth, or an EVERWhite micro-cloth.
- See the maintenance instructions sheet under resources on our website [everwhiteboards.com](http://everwhiteboards.com)



## EVERGlass Painted Magnetic Marker Board Limited Warranty

Painted magnetic marker boards are backed by a five (5) year limited warranty from the original date of purchase, subject to the terms and conditions outlined below.

### Warranty Coverage

#### Paint Finish

The painted surface is warranted not to peel, chip, or flake under normal interior use conditions.



#### Metal Backer

The metal backer is warranted against delamination. The installer is responsible for testing any adhesive products prior to application directly onto the painted surface. EVERWhite assumes no responsibility for paint peeling, chipping, or flaking caused by adhesives or installation materials applied to the painted surface. Samples are available upon request for compatibility testing.

#### Glass Quality

The glass used in back-painted magnetic marker boards conforms to ASTM C1036 standards regarding acceptable size and quantity of glass defects inherent to the manufacturing process.

### Warranty Claims

In the event of a defect covered under this warranty, EVERWhite must be notified in writing and provided with proof of the original purchase date.

EVERWhite's liability under this warranty is limited, at its sole discretion, to either:

- Replacement of the defective product at no charge, or
- Refund of the original purchase price paid for the product.

This warranty does not cover:

- Installation or labor costs
- Removal costs
- Shipping charges
- Any incidental or consequential damage not included on the original product invoice

EVERWhite reserves the right to inspect the product prior to approving replacement or refund.

### Conditions That Void This Warranty

This warranty shall be considered void if the painted magnetic marker board:

1. Is exposed to standing water or other liquids
2. Is installed outdoors
3. Is installed in environments subject to extreme temperature variations
4. Is damaged due to improper maintenance or cleaning activities



## EVERGlass Whiteboard Care & Maintenance Information

Proper care will help keep your glass whiteboard clean, bright, and performing properly for years of use. Follow these guidelines for regular cleaning, safe use, and maintenance.

### Recommended Writing Tools

Use high-quality dry erase markers only. Do not use permanent markers, paint markers, grease pencils, or any other non-dry erase writing tools.

### Recommended Magnets

For magnetic glass whiteboards, use neodymium magnets only.

### Approved Cleaning Materials

For routine cleaning and maintenance, use microfiber cloths, non-alkaline glass cleaner, non-ammonia-based glass cleaner, mild soap and water, clean water, isopropyl rubbing alcohol, and disinfectant wipes.

### Routine Cleaning

- For heavier cleaning, apply an approved cleaner to the cloth first. Then wipe the glass surface evenly.
- For stubborn marker residue or buildup, use isopropyl rubbing alcohol with a microfiber cloth.
- After cleaning, wipe the surface with clean water and dry thoroughly to help prevent streaking, haze, or leftover cleaning residue.

### Disinfecting the Surface

- Disinfecting wipes may be used when disinfecting is needed.
- After disinfecting, wipe the surface with clean water and a microfiber cloth. Dry the board completely to help prevent streaking, haze, or leftover cleaning residue.

### Important Cleaning Precautions

- Do not clean the glass when it is hot or in direct sunlight. Cleaning hot glass may cause streaking, cleaner residue, or uneven drying.
- Clean only the front writing surface. Do not spray or apply cleaner to the back of the painted glass board.
- Use only cleaners that are free of silicone, polishing abrasives, caustic chemicals, and harsh alkaline or ammonia-based ingredients.

### Do Not Use

To protect the glass surface, do not use razor blades, metal scrapers, metal tools, abrasive pads, scouring sponges, tape, stickers, labels, adhesives, silicone-based cleaners, polishing abrasives, caustic cleaners, or harsh alkaline or ammonia-based cleaners.

**SECTION 101100  
VISUAL DISPLAY UNITS**

**PART 1 GENERAL**

**1.01 SECTION INCLUDES**

- A. Glass markerboards.

**1.02 REFERENCE STANDARDS**

- A. 16 CFR 1201 - Safety Standard for Architectural Glazing Materials; Current Edition.
- B. ANSI Z97.1 - American National Standard for Safety Glazing Materials Used in Buildings - Safety Performance Specifications and Methods of Test; 2015 (Reaffirmed 2020).
- C. ASTM C1036 - Standard Specification for Flat Glass; 2025.
- D. ASTM C1048 - Standard Specification for Heat-Strengthened and Fully Tempered Flat Glass; 2025.

**PART 2 PRODUCTS**

**2.01 VISUAL DISPLAY UNITS**

- A. Glass Markerboards:
  - 1. Manufacturers:
    - a. EVERWhite
  - 2. Glass: Manufacturer's standard thickness, for use as dry erase board or projection surface
  - 3. Glass Finish: As selected from manufacturer's full range.
  - 4. Steel Backing Sheet Thickness: 28 gauge, 0.0149 inch (0.38 mm).
  - 5. Mounting: Z-Clip Brackets, Edge Grips, Through-Hole Grip

**2.02 MATERIALS**

- A. Float Glass: Provide float-glass-based glazing unless otherwise indicated.
  - 1. Kind FT - Fully Tempered Type: Comply with ASTM C1048.
  - 2. Fully Tempered Safety Glass: Comply with ANSI Z97.1 or 16 CFR 1201 criteria for safety glazing used in hazardous locations.
  - 3. Thickness: As indicated.

**2.03 ACCESSORIES**

- A. Marker Tray
- B. Rare Earth Magnets

**PART 3 EXECUTION**

**3.01 EXAMINATION**

- A. Verify that field measurements are as indicated.
- B. Verify that internal wall blocking is ready to receive work and positioning dimensions are as indicated on shop drawings.

**3.02 PREPARATION**

- A. Acclimatize markerboard panels by removing from packaging in installation area not less than 24 hours before application.
- B. Remove switchplates, wall plates, and surface-mounted fixtures where Markerboard are is applied. Reinstall items on completion of installation.
- C. Prepare surfaces using the methods recommended by the manufacturer for achieving the best result for the substrate under the project conditions.

**3.03 INSTALLATION**

- A. Install boards in accordance with manufacturer's instructions.
- B. Secure units level and plumb.

C. Butt Joints: Install with tight hairline joints.

**3.04 CLEANING**

A. Clean board surfaces in accordance with manufacturer's instructions.

B. Cover with protective cover, taped to frame.

C. Remove temporary protective cover at Date of Substantial Completion.

**END OF SECTION**

ZONE		REV	DESCRIPTION	DATE	APPROVED

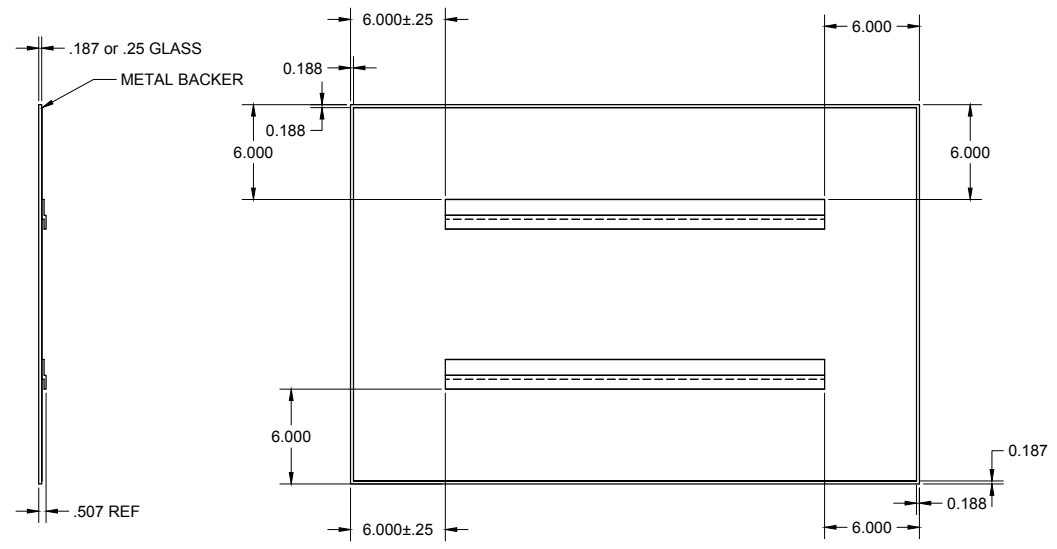

METAL BACKER  
 Z-CLIP WALL MOUNT  
 2 SIDED TAPE APPLIED

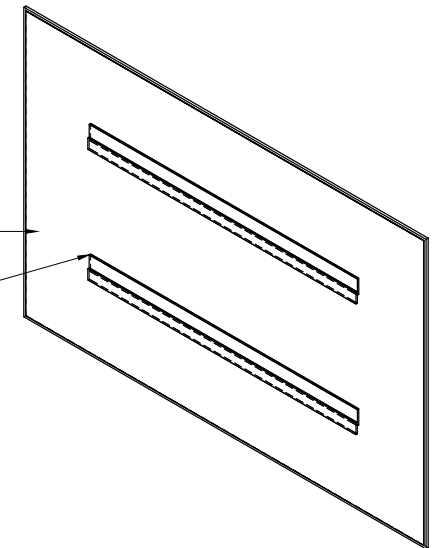

### GENERIC Z-CLIP LOCATION

<small>THE INFORMATION CONTAINED HEREIN IS CLASSIFIED "CONFIDENTIAL" IT IS THE SOLE PROPERTY OF SPECIALTY GLASS PROD. AND ANY USE THEREOF AND/OR REPRODUCTION THEREOF IS EXPRESSLY PROHIBITED WITHOUT WRITTEN CONSENT OF SPECIALTY GLASS PROD.</small>	DWG NAME		 <small>184 Railroad Drive, Warminster, PA 18974</small>
	MATERIAL		
	DRAWN BY	DATE	
<small>TOLERANCES UNLESS OTHERWISE SPECIFIED        .002 ± .010    .015 ± .005        .001 ± .000    ANGLE ±.00 DEG. 30 MIN.</small>	SCALE	DWG NO.	REV
			SHEET

# EVERGlass Whiteboard Installation Instructions

## Recommended Equipment

- Pencil
- Level
- Tape Measure
- Drill
- #2 bit
- Step Ladder (2-3 steps)

## Provided Equipment

- Glass Panel
- Brackets (2)
- 1 ¼" screws
- Wall Anchors

## Z-Clips Installation Diagram

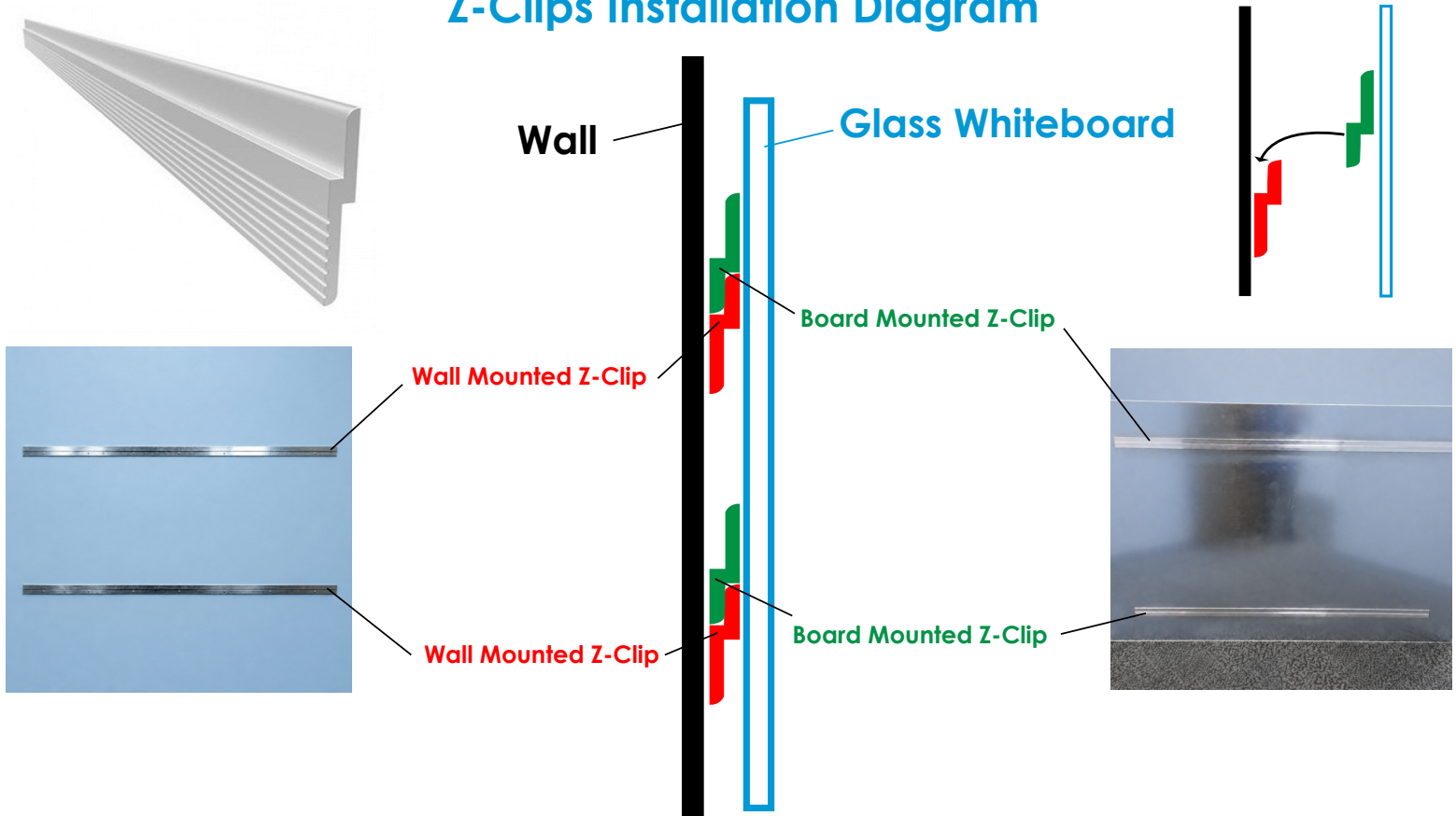

## Install Instructions for hanging EVERGlass Boards with Z-Clips

### IMPORTANT NOTE:

All glass installations should be carried out by two or more individuals.

**1** Use the correct mounting specification depending on the size and layout of your board. You may drill holes into the support bracket to install.

**2** Cut tape around perimeter of box, do not cut box itself. Doing so risks damaging glass.

- 3 Remove cardboard template from inside box.

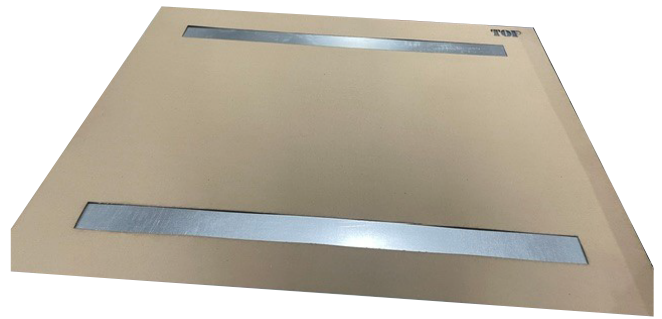

- 4 Remove wall mounted Z-Clips  
(Z-Clips taped to metal side of board with pre-drilled holes).

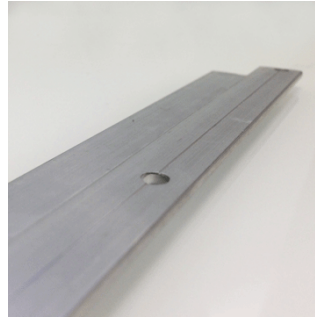

- 5 Position template in desired location on wall and secure with tape.

- 6 Mark the wall in the lower corners of each cutout then remove template from wall.

- 7 Position wall mounted Z-Clip so that the drilled holes are pressed against the wall and each lower corner is in line with marks made in step 5.



- 8 Secure wall mounted Z-Clip with screws.  
(If Drywall anchors needed; mark hole locations, remove Z-Clip, drill and insert anchors, replace Z-Clip and secure with screws.)



- 9 Repeat step 8 with other wall mounted Z-Clips, quantity varies depending on size of board.

- 10 Once wall mounted Z-Clips are attached to wall and secured, remove glass markerboard from box and remove any protective foam.

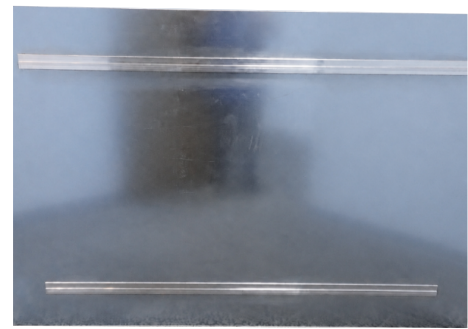

- 11 Position markerboard so that when mounted, the board z-clips interlock with wall mounted Z-Clips (Board Z-Clips raised portion facing down, wall mounted Z-Clips raised portion facing up)

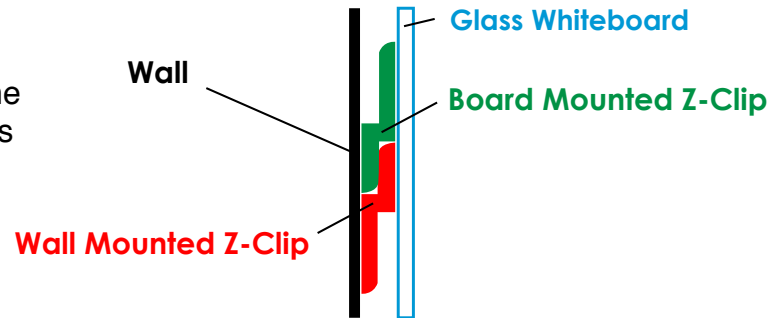

- 12 Lift markerboard towards location of wall mounted Z-Clips, raising above desired mounting height.



- 13 Slowly lower board onto wall mounted Z-Clips so that both Z-Clips lock with each other.

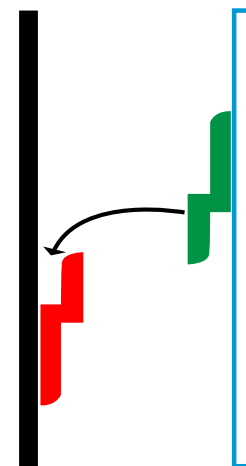

- 14 Confirm board is supported by all mounting points and is level.

# Installation Guidelines

## Edge Grip Standoffs

### Installation Tips

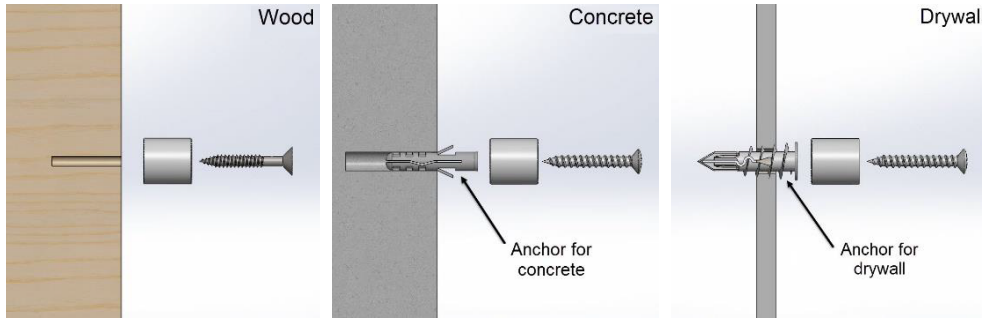

**Always check the installation surface to ensure that the substrate will be strong enough to hold the weight of the panel. All installation must be done so with proper hardware and protective gears to ensure safety. It is important to check that parts are properly tightened at the end of each installation.**

- 1 Using the panel as a template, mark the point on the installation surface for drilling. (Marking the grip locations on the panel is recommended).

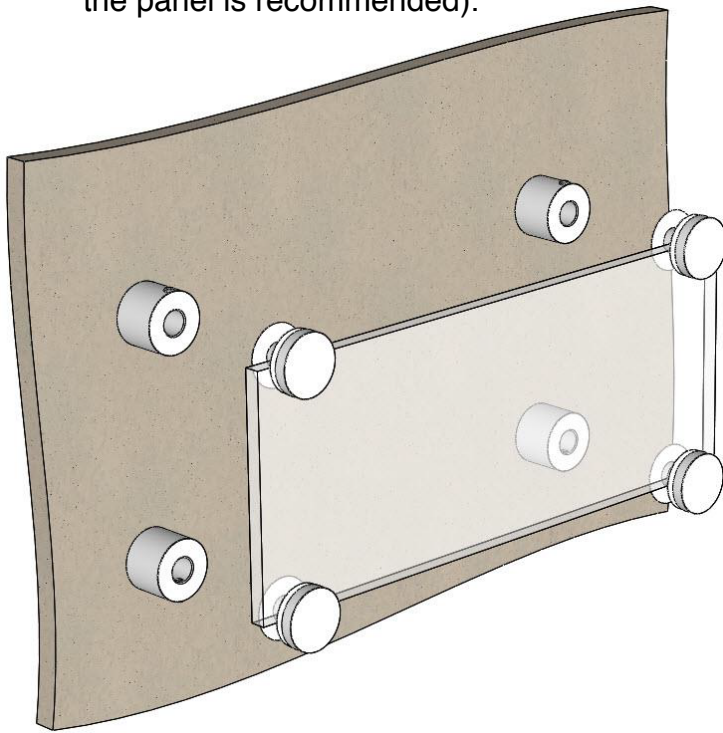

- 2 Install wall anchors. Use proper installation hardware

- 3 Install edge grips on the panels. Tighten the M4 set screw located inside the edge grip, after aligning the panels inside the edge grips.

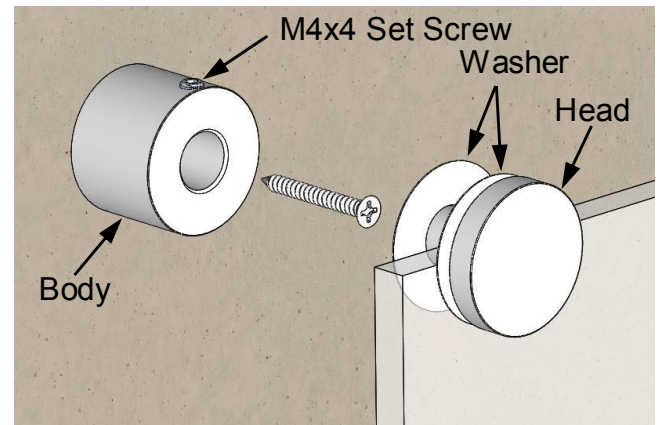

- 4 Slide the grips/panel onto the anchors. Tighten the outside M4 set screw once all grips are seated flush against the anchors.

It might be easier to gently tighten the set screws first to hold the grips/panel in place before going back to the set screws to completely tighten them.

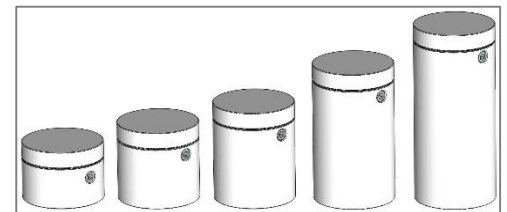

\* Installation instructions apply to any of the sizes that are available.

## Take Off Sheet

Date: \_\_\_\_\_ PG# \_\_\_\_\_ OF: \_\_\_\_\_

### Att: Estimating



Rm#	Qty.	Rm#	Qty.	Rm#	Qty.
_____ ( )	_____ ( )	_____ ( )	_____ ( )	_____ ( )	_____ ( )
_____ ( )	_____ ( )	_____ ( )	_____ ( )	_____ ( )	_____ ( )
_____ ( )	_____ ( )	_____ ( )	_____ ( )	_____ ( )	_____ ( )
_____ ( )	_____ ( )	_____ ( )	_____ ( )	_____ ( )	_____ ( )
_____ ( )	_____ ( )	_____ ( )	_____ ( )	_____ ( )	_____ ( )
TOTAL _____					
_____ ( )	_____ ( )	_____ ( )	_____ ( )	_____ ( )	_____ ( )
_____ ( )	_____ ( )	_____ ( )	_____ ( )	_____ ( )	_____ ( )
_____ ( )	_____ ( )	_____ ( )	_____ ( )	_____ ( )	_____ ( )
_____ ( )	_____ ( )	_____ ( )	_____ ( )	_____ ( )	_____ ( )
_____ ( )	_____ ( )	_____ ( )	_____ ( )	_____ ( )	_____ ( )
TOTAL _____					
_____ ( )	_____ ( )	_____ ( )	_____ ( )	_____ ( )	_____ ( )
_____ ( )	_____ ( )	_____ ( )	_____ ( )	_____ ( )	_____ ( )
_____ ( )	_____ ( )	_____ ( )	_____ ( )	_____ ( )	_____ ( )
_____ ( )	_____ ( )	_____ ( )	_____ ( )	_____ ( )	_____ ( )
_____ ( )	_____ ( )	_____ ( )	_____ ( )	_____ ( )	_____ ( )
TOTAL _____					

**CIRCLE BOARD CHOICES BELOW:**

Board Surface	Cork Color Options	Trim Options	Roll Options																																								
<ul style="list-style-type: none"> <li>•High Gloss Dry Erase Whiteboard</li> <li>•High Gloss Dry Erase Resurfacing Panel</li> <li>•ULTimatte Projection Board</li> <li>•ULTimatte Projection Resurfacing Panel</li> <li>•Forbo® Cork</li> <li>•Custom Printed</li> </ul>	<table style="width: 100%; text-align: center;"> <tr> <td style="width: 15%;"></td> <td style="width: 15%;"></td> <td style="width: 15%;"></td> <td style="width: 15%;"></td> <td style="width: 15%;"></td> </tr> <tr> <td>Autumn</td> <td>Charcoal</td> <td>Chili Pepper</td> <td>Cinnamon</td> <td>Clay</td> </tr> <tr> <td></td> <td></td> <td></td> <td></td> <td></td> </tr> <tr> <td>Cobalt Blue</td> <td>Fog</td> <td>Grass</td> <td>Natural</td> <td>Sand</td> </tr> <tr> <td></td> <td></td> <td></td> <td></td> <td></td> </tr> <tr> <td>Slate</td> <td>Stone</td> <td>Timber Wolf</td> <td>Wheat</td> <td>White Stone</td> </tr> </table>						Autumn	Charcoal	Chili Pepper	Cinnamon	Clay						Cobalt Blue	Fog	Grass	Natural	Sand						Slate	Stone	Timber Wolf	Wheat	White Stone	<ul style="list-style-type: none"> <li>•5/8" narrow aluminum</li> <li>•1-1/8" wide aluminum</li> </ul> <table style="width: 100%; text-align: center;"> <tr> <td></td> <td></td> <td></td> <td></td> <td></td> </tr> <tr> <td>Oak</td> <td>Maple</td> <td>Cherry</td> <td>Mahogany</td> <td>Black</td> </tr> </table> <ul style="list-style-type: none"> <li>•1-1/4" narrow wood</li> <li>•1-7/8" wide wood</li> </ul>						Oak	Maple	Cherry	Mahogany	Black	<ul style="list-style-type: none"> <li>•With marker tray</li> <li>•Without marker tray</li> <li>•1" map and display Rail (shown below)</li> </ul>
Autumn	Charcoal	Chili Pepper	Cinnamon	Clay																																							
Cobalt Blue	Fog	Grass	Natural	Sand																																							
Slate	Stone	Timber Wolf	Wheat	White Stone																																							
Oak	Maple	Cherry	Mahogany	Black																																							

**NOTE:** Fill in dotted lines and indicate board type as follows:

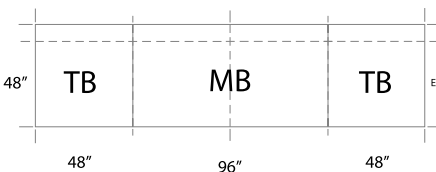
TB=Tack Board, MB=Markerboard



Job Name \_\_\_\_\_ Consignee Zip Code \_\_\_\_\_ ETA of Project \_\_\_\_\_

Distributor Name \_\_\_\_\_ Architect's Name \_\_\_\_\_

Estimator \_\_\_\_\_ Architect's Address \_\_\_\_\_

Phone \_\_\_\_\_

## EVERWhite Whiteboards

Whiteboards | Resurfacing Solutions | Corkboards