

EVER *White*®



**Guaranteed to Stay
White for a Lifetime.**

Find us in

MasterSpec®

a product of The American Institute of Architects

**PRODUCT
CATALOG**

Division 9 + 10

“the **best dry erase board** we have tried”

- Bryan Hunter
Maintenance Supervisor
Lawrence Public Schools
Lawrence, KS

“It takes 20 minutes to install a resurfacing panel - no drilling, no screwing, nothing to do except peel and stick. **That makes my job easier.**”

- Mike Meyers
Buildings & Grounds Manager
Rice Lake School District
Rice Lake, WI

“the boards **stay white** and we don't receive complaints”

- Jim White
Architect
Colorado State University
Fort Collins, CO

“the boards are **extremely durable**”

- Courtney Kudey
Regional Facility Director
Reuters
New York, NY

Table of Contents

- 1 EVERWhite
- 2 Ordering Details
- 3 Products

Resurfacing Solutions

- 4 **Everase** High Gloss Resurfacing Material
- 5 Before and After Examples
- 6 Printed Dry Erase Resurfacing Material
- 7 Printed Dry Erase Resurfacing Material
- 8 Commercial Erasable Wallcovering
- 9 Custom Printed Commercial Erasable Wallcovering
- 10 Clear Dry Erase Laminates
- 11 Technical Performance of Everase Surfaces
- 12 **EverEZ** Resurfacing Panels
- 13 Resurfacing Panel Measurement Form

Whiteboards

- 14 Aluminum Framed Whiteboards
- 15 Wood Framed Whiteboards (Wide)
- 16 Wood Framed Whiteboards (Narrow)
- 17 **ULTImatte** 5-Foot Tall Matte Projection Whiteboards
- 18 **EDISONSeries** Plain Mobile Whiteboards

Printed Whiteboards

- 19 Printed Mobile Whiteboards
- 20 Education Whiteboards
- 21 EZGrid Ghost Whiteboards
- 22 Calendar Whiteboards
- 23 Coaching Whiteboards
- 24 **Custom Shop** Custom Printed Whiteboards
- 25 Custom Printed Gallery
- 26 Custom Printed Whiteboards
- 27 Custom Printed Magnetic Overlays

Re-Stic Dry Erase Surfaces

- 28 - 29 Plain Re-Stic Dry Erase Surfaces
- 30 - 31 Standard Printed Re-Stic Dry Erase Surfaces
- 32 - 33 Custom Printed Re-Stic Dry Erase Surfaces

Cork Boards

- 34 Aluminum Framed Cork Bulletin Boards
- 35 Wood Framed Cork Boards

Combination Boards

- 36 Aluminum Framed Combination Boards
- 37 Wood Framed Combination Boards - Magnetic

Accessories

- 38 Accessories

Testimonials

- 39 Testimonials

order online

www.everwhiteboards.com

order by phone

800-335-7319

order by email

sales@everwhiteboards.com

- ✓ **Long-Term Savings**
- ✓ **Low Maintenance**
- ✓ **Zero Complaints**

Order Here



EVER *White*®

Guaranteed to Stay White for a Lifetime.



EVERWhite Whiteboards Stay White and Bright—GUARANTEED!

EVERWhite dry erase boards eliminate ghosting and staining. Even permanent marker ink can be removed!

Unlike traditional melamine or porcelain dry erase surfaces, the EVERWhite surface is nonporous and does not allow marker ink to penetrate. The result is a whiteboard that never needs to be replaced due to ghosting or staining.

When you choose EVERWhite, you'll be joining thousands of satisfied EVERWhite customers who never again have to worry about replacing stained whiteboards.

Thousands of educational institutions, businesses, and health-care facilities around the country trust the EVERWhite name to provide important benefits:

- **Savings.** Backed by one of the best warranties in the industry—a lifetime guarantee against staining—you'll never have to replace dull, stained whiteboards again. And, as both the manufacturer and seller of EVERWhite products, we're able to provide you with factory-direct prices with no markup from a middleman.
- **Engaging presentations.** The stain-free surface remains as white as the day your board was installed, so you'll never have to worry about marker ink stains interfering with writing.

- **Easy maintenance.** No need for expensive cleaners. The guaranteed-to-clean EVERWhite surface remains white with occasional cleaning using water or household glass cleaner and a soft cloth.
- **Affordable customization.** Experts at customization, we're able to provide boards for your specific needs at affordable prices—no matter how large or small your order.
- **Environmental benefits.** EVERWhite whiteboards include recycled materials, and EVERWhite resurfacing panels prevent old chalkboards and whiteboards from being discarded in landfills.
- **Unmatched customer service.** Your satisfaction is our priority. Let us help you find the right products for your needs. Amazing whiteboards with amazing service—that's the EVERWhite Advantage!

You'll cut costs, prevent complaints, and save valuable time with EVERWhite.

Ordering Details

Ordering Resurfacing Panels

Before ordering resurfacing panels, reading the resurfacing panel measurement instructions is recommended to ensure correct measurements are taken. Instructions on how to measure your existing boards to order panels are available on our website. Reading installation instructions before installation is highly recommended because the aggressive adhesive backing on resurfacing panels is very strong, and it is difficult to remove if a mistake is made during installation. Panel installation instructions are included in shipments of panel orders and are available on our website.

Magnetic vs. Non-Magnetic Surfaces

If you do not need your dry erase board to hold magnetic accessories, choosing a non-magnetic surface will save money. Both magnetic and non-magnetic EVERWhite boards are the same surface with a lifetime guarantee against ghosting and staining.

Care and Maintenance

Use our microfiber EVERCloth with water, dry erase cleaner or glass cleaner to keep your EVERWhite whiteboard looking new for a lifetime. To erase permanent marker, simply write over the permanent marker with dry erase marker, and erase. Or, to remove permanent marker from large areas, contact us for recommended cleaners. No harsh cleaners are required to remove marker ink from an EVERWhite board. Never use cleaners with abrasives or scouring pads, as they can ruin the dry erase surface. See our complete care and maintenance instructions on our website.

Lifetime Guarantee

At EVERWhite, our name is our promise. Our products are proudly manufactured in the USA and are guaranteed not to stain for a lifetime. If EVERWhite dry erase boards have any staining under normal usage and with maintenance that follows the care and use instructions included with the boards, we'll replace them. Use of abrasive cleaners, substances or sharp instruments may scratch the surface and are not covered by the warranty. The warranty is only valid for the original purchasing entity. EVERWhite products are designed to be installation-ready, however, installation and the installation environment are out of EVERWhite's control and therefore installation is not warranted by EVERWhite in any circumstance. To file a claim, contact EVERWhite customer service at (800) 335-7319.

Architects and Contractors

EVERWhite has specifications, CAD drawings and BIM models available on www.everwhiteboards.com. We invite all contractors to add EVERWhite to your bid list. EVERWhite provides competitive pricing and fast delivery on bid shipments.

Terms and Conditions

All prices are based on quantity discounting and F.O.B. origin. Freight is prepaid and added excluding locations outside the continental U.S., which will be shipped freight prepaid and added to any port in the continental United States. EVERWhite reserves the right to change prices and specifications without prior notice. Prices are effective as of the date specified on the back cover of this catalog and supersede all previously published catalogs. Charges are payable upon receipt of product. Prices listed are for standard products. Additional charges apply for modifications such as custom cutting, custom sizes and custom frames. All whiteboards and resurfacing panels are made to order and are non-returnable. When ordering wood framed boards, please allow for naturally occurring variations in color, grain and character marks.

Freight Responsibility

Please inspect your delivery before signing the delivery receipt.

It is advisable to unpack your delivery and check for concealed damage. Your delivery should appear in good condition and in accordance with the quantity indicated on the delivery receipt.

Please note any damage on the bill of lading before signing the delivery receipt, and notify EVERWhite within 2 days to report damage. It is the customers' responsibility to unload shipments. For

inside delivery options, please inquire with EVERWhite customer service. Additional charges may apply. Before ordering large boards, please make sure they are not too large to be transported through-out your facility. For more information about shipping, please visit: <https://everwhiteboards.com/whiteboard-resources/shipping-information/>

Ground Shipments

Most items up to and including products sized 36" x 48" or under can be shipped via UPS. All other larger products are shipped via freight carrier.

Contact Us

EVERWhite
184 Railroad Drive
Warminster, PA 18974
phone: (800) 335-7319
fax: (215) 323-4135
sales@everwhiteboards.com
www.everwhiteboards.com

Products

For details on the various types of EVERWhite boards and resurfacing panels, please see the product descriptions below. All of the following products feature the lifetime guaranteed EVERWhite dry erase surface.



Resurfacing Solutions

EverErase Resurfacing Material

Our resurfacing material installs over existing chalkboards or dry erase boards with a factory applied self adhesive backing and can be trimmed to fit precisely within any existing frame.

EverEZ Resurfacing Panels

Transform old whiteboards or chalkboards into new whiteboards in minutes with EverEZ Resurfacing Panels. Custom cutting is available to fit within the frames of your existing boards. Resurfacing panels consist of the EVERWhite dry erase surface backed by a layer of 24-gauge treated steel with a factory applied pressure-sensitive self-adhesive backing for easy installation. Just peel and stick!

Aluminum Framed Whiteboards

For a sleek, contemporary look, choose our tempered aluminum frames enhanced with a satin, clear anodized finish. Aluminum frames are available in narrow or wide widths, with or without marker trays. Marker trays feature durable, molded snag-free end caps.

Wood Framed Whiteboards

For an ultra-sophisticated look, select one of our high-quality wood framing finishes—oak, maple, cherry stain, or mahogany stain. Wood frames are available in narrow or wide widths, with or without marker trays.

5-Foot Matte Projection Whiteboards

Get an extra foot, or 20% more space compared to a traditional 4-foot whiteboard with an EVERWhite 5-foot tall whiteboard. The low-glare surface is ideal for projection as it supports use as a video projection whiteboard. Despite the matte surface, the dry erase is still easy to clean and always stays white.

Mobile Whiteboards

Get twice the classroom writing space with EVERWhite's Double-Sided Mobile Magnetic Dry Erase Board with Aluminum Frame. Simply turn the pivot knob on the frame to flip the board over, and lock it in place to start writing. The EVERWhite surface resists ghosting and accepts magnets. Holds markers and EVERCloths in the full-length accessory tray. Choose from five available sizes.

Cork Bulletin Boards

Cork Bulletin Boards include crumble-resistant, selfhealing cork that will never peel, crack and reduces pinholes. Choose from fifteen available colors.

Cork/Dry Erase Combination Boards

Part whiteboard and part bulletin board, these boards feature both the EVERWhite dry erase surface and a tack able surface. Available in four customizable configurations.

Education Printed Whiteboards

Designed with the teacher or professor in mind, Education Printed Whiteboards feature helpful classroom graphics. Graphics are embedded underneath the dry erase surface, so they will never wear away or interfere with writing.

EZ Grid Whiteboards

With three unique grid designs to choose from, these ghosted patterns provide a guide for drawing and writing, but are barely visible to people viewing presentations. All patterns are printed below the dry erase surface and will never wear away or interfere with writing.

Calendar Whiteboards

1-Month, 2-Month, 3-Month, 4-Month, 6-Month and 12-Month calendar options are available in various colors to help you stay organized all month, quarter or year long. Month and date magnet accessory sets are available for additional purchase.

Sports and Recreation Printed Whiteboards

Customized to fit the needs of any coach or trainer, Sports and Recreation Printed Whiteboards feature customized graphics such as strength and conditioning charts, rosters, or court/field diagrams that are embedded underneath the EVERWhite surface. Graphics will never wear away or interfere with writing.

Custom Printed Whiteboards

EVERWhite Custom Printed Whiteboards feature the stain-free EVERWhite surface with customized graphics such as charts, calendars, logos, or diagrams are embedded underneath the dry erase surface and will never fade or wear away. Choose from various standard or customized framing options to match the aesthetics of your school, office, healthcare facility, production plant, or anywhere.

Graphic Magnetic Overlays

Looking to make your whiteboard more versatile? EVERWhite Graphic Magnetic Overlays can be customized with your specific graphics and applied to wall-mounted and mobile whiteboards. All you need to do is apply your overlay to your magnetic whiteboard to get a new custom dry erase surface.

Accessories

EVERWhite has a wide range of whiteboard accessories, including cleaner, dry erase markers, microfiber cloths, maprails, and more.

Everase High Gloss Resurfacing Material

Everase's Dry Erase High Gloss Resurfacing Material features our high-quality writing surface with a high gloss finish. Our simple resurfacing process is the quickest, easiest and most affordable solution to transform an old chalkboard or inferior stained and ghosted whiteboard into a new dry erase board. Our resurfacing material installs over existing chalkboards or dry erase boards with a factory applied self adhesive backing and can be trimmed to fit precisely within any existing frame. Instructions and a video for simple installation are included.

Features and Benefits:

- Easy, Do-It-Yourself Installation at 30 minutes per board
- Excellent Erasability & Durability
- Permanent marker can easily be removed
- Non-yellowing, non-chalking, non-ghosting
- Cleans without the use of cleaners, just water and a cloth
- Abrasion, Chemical, Heat, Scratch, Stain & Solvent Resistant
- Ships as a roll by FedEx/UPS Ground
- 10-year limited warranty
- Manufactured in the USA

Applications:

- Classrooms
- Conference rooms and think tanks
- Collaborative environments
- Walls and desks
- And more!

Specifications:

- Heights: 50" and 61"
- Lengths: 9 ft., 17 ft., 56 ft., and 100 ft.
- Custom Lengths available upon request
- Thickness: 11 mil
- Surface Finish: White High Gloss Dry Erase
- Adhesive: Aggressively removable pressure sensitive adhesive
- Release Liner: Siliconized paper

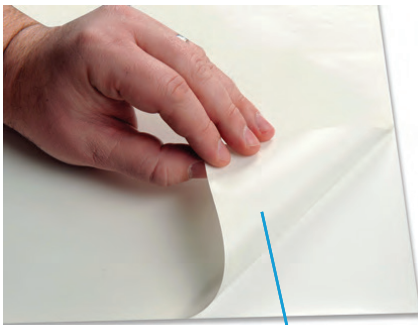

Pressure Sensitive Adhesive



Dry Erase Resurfacing Material (50 inch)

Item #	Size	Weight	Package Dimensions
AA11NA-9	9 ft. x 50"	13 lbs.	9" x 9" x 54"
AA11NA-17	17 ft. x 50"	17 lbs.	9" x 9" x 54"
AA11NA-56	56 ft. x 50"	39 lbs.	9" x 9" x 54"
AA11NA-100	100 ft. x 50"	61 lbs.	9" x 9" x 54"

Dry Erase Resurfacing Material (61 inch)

Item #	Size	Weight	Package Dimensions
AA11NC-9	9 ft. x 61"	15 lbs.	9" x 9" x 63"
AA11NC-17	17 ft. x 61"	20 lbs.	9" x 9" x 63"
AA11NC-75	75 ft. x 61"	58 lbs.	9" x 9" x 63"

Custom lengths can be available upon request

Please contact us for custom sizes or for discounted pricing on large quantities.

Dry Erase Resurfacing Solutions Before and After

EVER *White*®

Dry Erase Resurfacing Solutions
www.everwhiteboards.com
800-335-7319

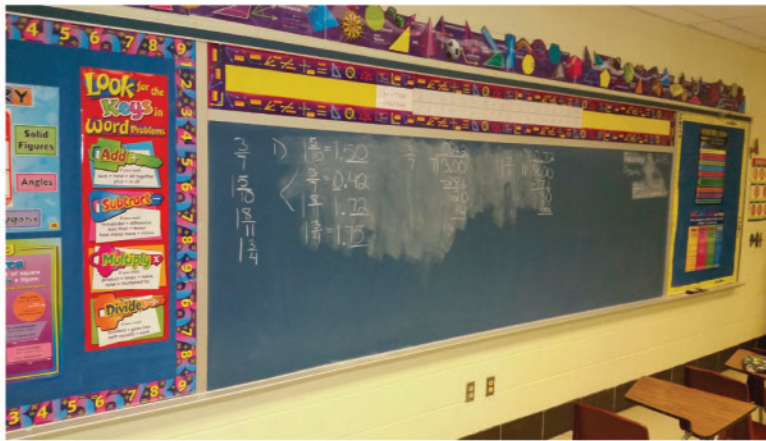
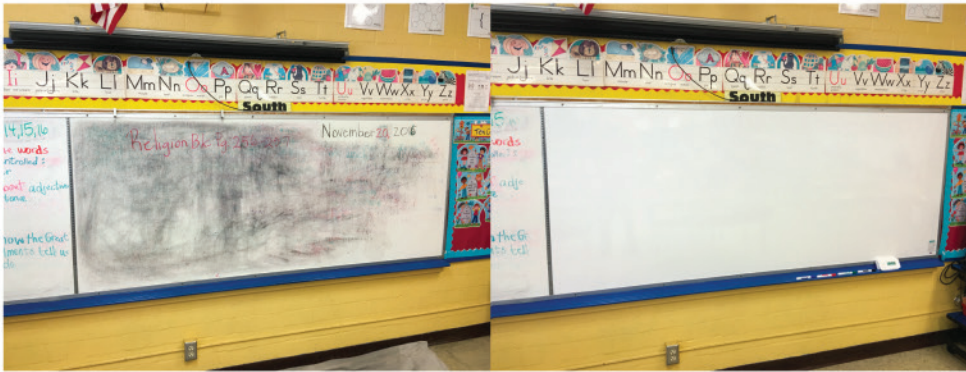

Printed Dry Erase Resurfacing Material

Everase's Printed Resurfacing Material features our ultra crisp, digitally printed graphics embedded under our high-quality dry erase writing surface. Various standard prints are available such as Music Staff, Penmanship Lines, Traceable Grid and Traceable Graph. We even have the capabilities to customize the writing surface with your own ideas and graphics. This printed product will have the same ease of use with excellent erasability and stain resistance as our signature Everase whiteboard surface. It easily installs directly over existing chalkboards or dry erase boards with a factory applied self-adhesive and can be trimmed to fit an existing frame. Instructions and a video make installation a breeze.

Specifications:

- Heights: 50"
- Lengths: 100 ft.
- Custom Lengths available upon request
- Thickness: 8 mil
- Surface Finish: White High Gloss Dry Erase with print design
- Adhesive: Aggressively removable pressure sensitive adhesive
- Release Liner: Siliconized paper



Features & Benefits:

- Easy, Do-It-Yourself Installation at 30 minutes per board
- Excellent Erasability & Durability
- Abrasion, Chemical, Heat, Scratch, Stain and Solvent Resistant
- Non-yellowing, non-chalking, non-ghosting product
- Digital print embedded under dry erase surface
- Cleans without the use of cleaners, just water and a cloth
- Ships as a roll by FedEx/UPS Ground
- 10-year limited warranty
- Manufactured in the USA

Applications:

- Classrooms
- Music, math and reading rooms
- Conference rooms and think tanks
- Collaborative environments
- And more!



Printed Resurfacing Material (50 inch)

Product Name	Item #	Size	Weight	Package Dimensions
Music Staff	AA12NA-100	100 ft. x 50"	61 lbs.	9" x 9" x 54"
Penmanship	AA13NA-100	100 ft. x 50"	61 lbs.	9" x 9" x 54"
Traceable Graph	AA14NA-100	100 ft. x 50"	61 lbs.	9" x 9" x 54"
Traceable Grid	AA15NA-100	100 ft. x 50"	61 lbs.	9" x 9" x 54"

Custom lengths can be available upon request



Please contact us for custom sizes or for discounted pricing on large quantities.

Printed Resurfacing Material

Music Staff Lines

- Music Lines - 4 sets of music staves with 1" space between lines
4" between sets
(5 sets available upon request)

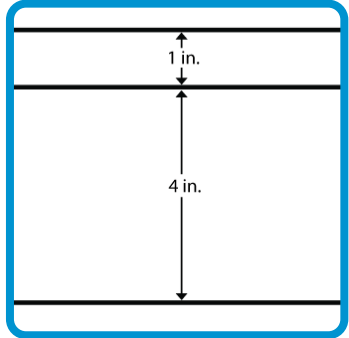
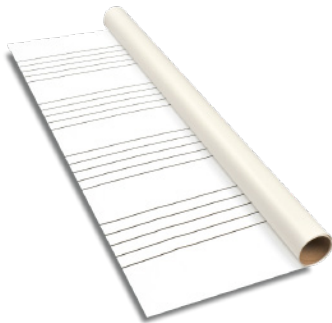

Penmanship Lines

- Penmanship Lines - 4" wide writing space

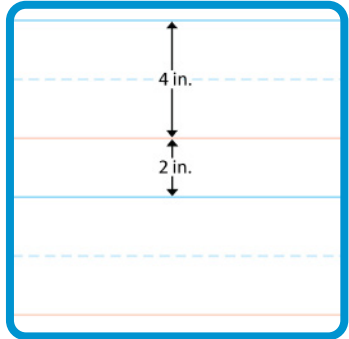

Traceable Grid

- Traceable Grid - 2" space

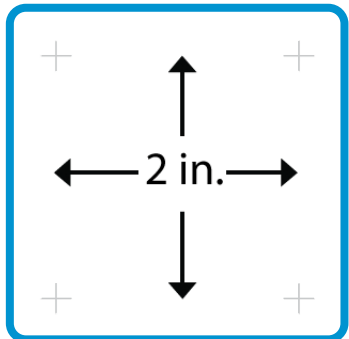

Traceable Graph

- Traceable Graph - 1" space

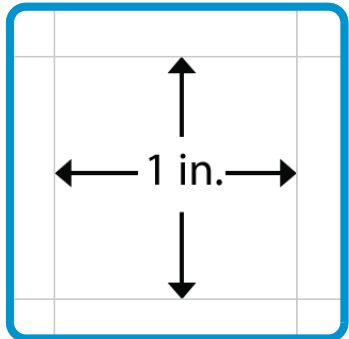
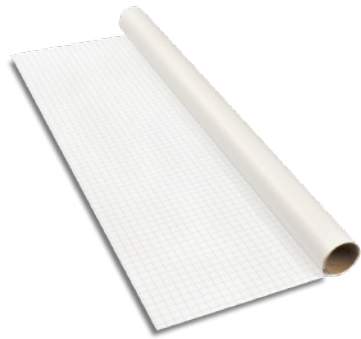

Custom printed designs are available

Please contact us for custom sizes or for discounted pricing on large quantities.

Commercial Erasable Wallcovering

Everase's Commercial Erasable Wallcovering brings our one-of-a-kind dry erase surface to your conference rooms, training areas, or any area where people gather to collaborate. This wallcovering can be installed the same as any commercial-grade vinyl wallcovering. By adhering vertical strips/floor-to-ceiling, you can cover just one wall or an entire room. If preferred, you can "railroad" this material horizontally around the room. Transform any space into a creative hub with Commercial Erasable Wallcovering to promote limitless brainstorming and creativity in any setting!



Product Specifications:

- **Width:** 60"
- **Length:** 50 ft.
- Custom widths and lengths available upon request
- **Surface Finish:** White High Gloss Dry Erase
- **Backing:** Nonwoven
- **Thickness:** 18.5 mil

Features & Benefits:

- Compatible with interactive technology or used as projection screens.
- Covers wall-to-wall and floor-to-ceiling or any flexible wall customization
- Passes ASTM E-84 Flammability Test as Class A for flame spread and smoke generation
- Cost-effective when compared to paint and other wallcovering options
- Can easily be cut with scissors for very specific shapes and sizes

Commercial Erasable Wallcovering

Name	Item #	Size	Weight	Package Dimensions
White - High Gloss, Nonwoven	AA31ND-50	50 ft. x 60"	44 lbs.	9" x 9" x 63"

Custom lengths can be available upon request



Please contact us for custom sizes or for discounted pricing on large quantities.

Commercial Erasable Wallcovering

Custom Printed Commercial Wallcovering

Promote limitless brainstorming and imagination by transforming your space into a creative outlet with a Custom Printed Commercial Wallcovering! This wallcovering can be custom printed with high quality digital images and colors embedded under the dry erase surface for maximum protection. The material is installed the same as any commercial-grade vinyl wallcovering. By adhering vertical strips/- floor-to-ceiling, you can cover just on wall or an entire room. Panels can also be installed in a "railroad" pattern if you prefer the panels to be horizontal. Transform any wall into a creative hub or decorative space with a Custom Printed Commercial Wallcovering!

Product Specifications:

- **Width:** 60"
- **Length:** Various custom lengths
- Custom widths and lengths available upon request
- **Surface Finish:** White High Gloss Dry Erase
- **Backing:** Nonwoven
- **Thickness:** 18.5 mil

Features & Benefits:

- Covers wall-to-wall and floor-to-ceiling or any flexible wall customization
- Vibrant, digital quality images and colors
- Digital print embedded under dry erase surface
- Passes ASTM E-84 Flammability Test as Class A for flame spread and smoke generation
- Compatible with interactive technology or used as projection screens
- Cost-effective when compared to paint and other wallcovering options



Contact us for a quote!



Please contact us for custom sizes or for discounted pricing on large quantities.

Clear Dry Erase Laminates

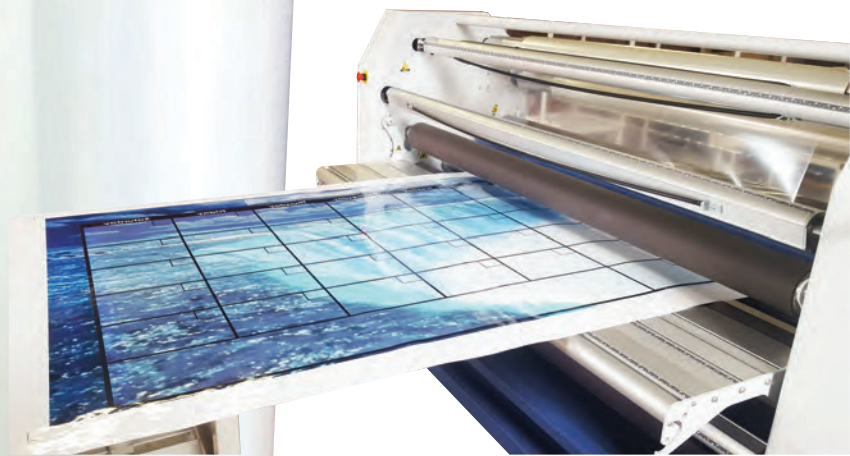

Clear Dry Erase Overlaminates

Name	Item #	Size	Weight	Package Dimensions
ClearFilms - 3 mil Dry Erase with PSA, 150 ft. roll x 51" wide	CLER-0211-51	150 ft. x 51 in	27 lbs.	5" x 5" x 53"
ClearFilms - 3 mil Dry Erase with PSA, 50 ft. roll x 51" wide	CLER-0211-51	50 ft. x 51 in.	12 lbs.	5" x 5" x 53"
ClearFilms - 3 mil Dry Erase with PSA, 150 ft. roll x 61" wide	CLER-0211-61	150 ft. x 61 in.	32 lbs.	8" x 8" x 64"
ClearFilms - 3 mil Dry Erase with PSA, 50 ft. roll x 61" wide	CLER-0211-61	50 ft. x 61 in.	15 lbs.	8" x 8" x 64"

Use Everase Dry Erase ClearFilms to enhance, protect, or add value to your graphics. From printing to signage, posters, custom dry erase boards and more. This Dry Erase Overlay allows you to laminate, write, and erase on virtually any surface. Like our other Dry Erase Solutions, there is never any ghosting or staining. Everase uses a premium polyester laminate with optically clear PSA to protect an array of graphics and signage. This cutting edge formula has allowed us to engineer our clear Dry Erase product line, and now it's available to you to put on virtually any surface!

Features & Benefits:

- Premium polyester overlaminates can be applied to various substrates using industry standard laminating equipment
- Optically clear pressure sensitive adhesive
- Dry erase technology is resistant to ghosting and staining
- Anti-Graffiti properties enables permanent marker to be erased easily
- Radiation cured hardcoat is chemical and scratch resistant

Product Specifications:

- **Width:** 51" and 61"
- **Lengths:** 50 ft. and 150 ft.
- Custom Lengths available upon request
- **Thickness:** 3 mil (2 mil polyester, 1 mil adhesive)
- **Surface Finish:** Clear High Gloss Dry Erase polyester film
- **Adhesive:** Optically clear permanent acrylic pressure sensitive adhesive

Applications:

- Signage
- Displays
- Point of purchase
- Printers
- Posters
- Fine art protection
- Custom Printed Dry Erase Boards:
 - Hospital boards
 - Planning schedules
 - Maps
 - Specials/menu boards
 - Calendars
 - Athletic Diagrams
 - and more!

Please contact us for custom sizes or for discounted pricing on large quantities.

TECHNICAL PERFORMANCE OF EVERASE® SURFACES

Our specifically engineered dry erase composite surface provides excellent printability and erasability in an impervious formulation. Everase offers the best quality features of scratch, chemical, stain, heat, and wear resistance and remains unsurpassed when compared and contrasted with our competition.

FEATURES	PROPERTY	RESULT
WRITEABILITY	Use of any dry erase, fluorescent, semi-permanent, and permanent markers and crayons will not damage the Everase surface.	Better than comparable products
ERASABILITY	Dry erasability using Boone 30 day test method	5 lbs/3 rubs or better with all tested dry erase markers*
	Gloss at 60 degrees using BYK Gardner / Micro-TRI-Gloss Test Method	100%
VISIBILITY	Excellent contrast compared to chalkboards. Allows for multi-color presentations	Excellent
PRINTABILITY	Excellent marker pen printability and erasability	Better than comparable products
	Non-ghosting, non-yellowing product	
	Both permanent and dry erase markers can be used for permanent and temporary information but then cleaned easily	
DURABILITY	Scratch resistance using Hoffman Scratch Test	700
	Hardness - Pencil using ASTM D3363-74	7H
WEARABILITY	Abrasion resistance using Taber Abrasion / 500 g - CS-10 Wheel	500 cycles
	Wear resistance using BYK Gardner Sled	5000 cycles
STAIN RESISTANCE	NEMA LD3-2000 3-4 Stain Resistance Report	Coffee, Tea, Mustard, Black permanent marker, #2 Pencil, Wax Crayon, Lipstick: 0 (No effect)
CHEMICAL RESISTANCE	ASTM D-1308 Method B-24 Report	Glass Cleaner - No stain Rubbing alcohol - No stain MEK (Methyl Ethyl Ketone) - No stain

These lab results are provided as a service only. All products are sold upon condition that the purchaser shall make their own tests and judgments. No warranty of merchantability or fitness for any purpose is implied by these test results, neither does this constitute the seller's product specifications. Everase® is a Registered Trademark. * Test Method and Results are available upon request.

Please contact us for custom sizes or for discounted pricing on large quantities.

EverEZ Resurfacing Panels

- Transforms any old chalkboard or stained whiteboard into a new whiteboard in minutes
- Fast and easy installation
- Factory applied self-adhesive
- Lifetime guaranteed non-staining surface
- Permanent marker resistant
- Magnetic
- Contact us for custom graphic panels (logos, calendars, etc.) or for standard print graphic panels (music staves, gridlines, penmanship lines and charts shown below)



All panels larger than 4'x12' are manufactured as multiple pieces of equal size with an H-channel seam (shown right) in the middle, unless otherwise specified.



EverEZ Magnetic Resurfacing Panel (L1000)

Size (HxW)

1' x 1'

1.5' x 2'

2' x 2'

2' x 3'

2' x 4'

3' x 4'

4' x 4'

4' x 5'

4' x 6'

4' x 8'

4' x 10'

4' x 12'

4' x 16'

4' x 20'

4' x 24'

Please contact us for custom sizes or for discounted pricing on large quantities.



Use this form to determine the perfect measurements for your EverWhite Resurfacing Panel.

All boards 4' x 12' or smaller ship as one piece. All boards over 4' x 12' will ship as multiple pieces of equal size, unless otherwise indicated.

Measurement Instructions: Measuring within the existing frame, take three vertical measurements and three horizontal measurements as shown in diagrams A and B below. Subtract 1/16" from the smallest vertical dimension and subtract 1/8" from the smallest horizontal dimension.

Measuring Tips:

1. Always use two people when taking measurements.
2. Always measure twice.
3. When measuring boards with map rails, if you do not plan to remove the map rail for installation, measure from the bottom of the board to the bottom lip of the map rail. If you do plan to remove the map rail for installation, measure from the bottom of the board to the upper lip of the map rail.

Single Piece Board (contains no seams)

Vertical Measurement:

Diagram A

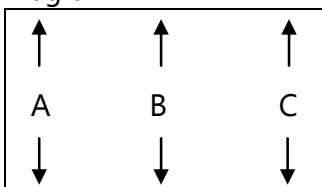

Horizontal Measurement:

Diagram B

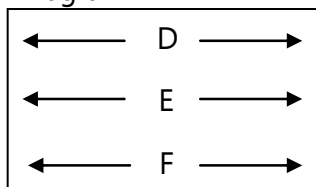

Measurement "A" _____

Measurement "B" _____

Measurement "C" _____

Shortest Measurement of A, B, & C: _____

Less 1/16" = _____

Measurement "D" _____

Measurement "E" _____

Measurement "F" _____

Shortest Measurement of D, E, & F: _____

Less 1/8" = _____

Multiple Piece Board (contains seams)

- Check box if your board consists of multiple pieces (separated by a seam or channel).
- If your board has a non-removable seam cover/channel, measure each section separately making the vertical and horizontal adjustments indicated in the form above. You may need multiple measurement forms.
 - If your board has a seam cover/channel that you will be removing prior to installation of your new panels, measure the board as one full unit (dimensions of the entire board), making the vertical and horizontal adjustments indicated in the form above.

Quantity of boards needed at this size : _____

Please supply a price quote for this board:

Please place an order for this board:

Room Number/Name _____

For a price quote or to place an order, please fax this form to (215) 335-7319, email this form to sales@everwhiteboards.com, or call us at (800) 335-7319.

Aluminum Framed Whiteboards

- Best erasability of any whiteboard, easiest to clean and surface stays bright and white
- Lifetime guaranteed non-staining, non-porous surface
- Permanent marker resistant
- Magnetic or Non-Magnetic options available
- 5/8" narrow aluminum frame (1-1/8" wide available upon request)
- Aluminum marker tray with no-snag end caps option available at no extra cost
- Whiteboard thickness is 1/2"
- Includes all mounting hardware; easy to install



All boards larger than 4'x12' are manufactured as multiple pieces of equal size with an H-channel seam (shown left) in the middle, unless otherwise specified.



Aluminum Framed Magnetic Whiteboard

Size (HxW)

1' x 1'

1.5' x 2'

2' x 2'

2' x 3'

2' x 4'

3' x 4'

4' x 3'

4' x 4'

4' x 5'

4' x 6'

4' x 8'

4' x 10'

4' x 12'

4' x 16'

4' x 20'

4' x 24'

Aluminum Framed Non-Magnetic Whiteboard

Size (HxW)

1' x 1'

1.5' x 2'

2' x 2'

2' x 3'

2' x 4'

3' x 4'

4' x 3'

4' x 4'

4' x 5'

4' x 6'

4' x 8'

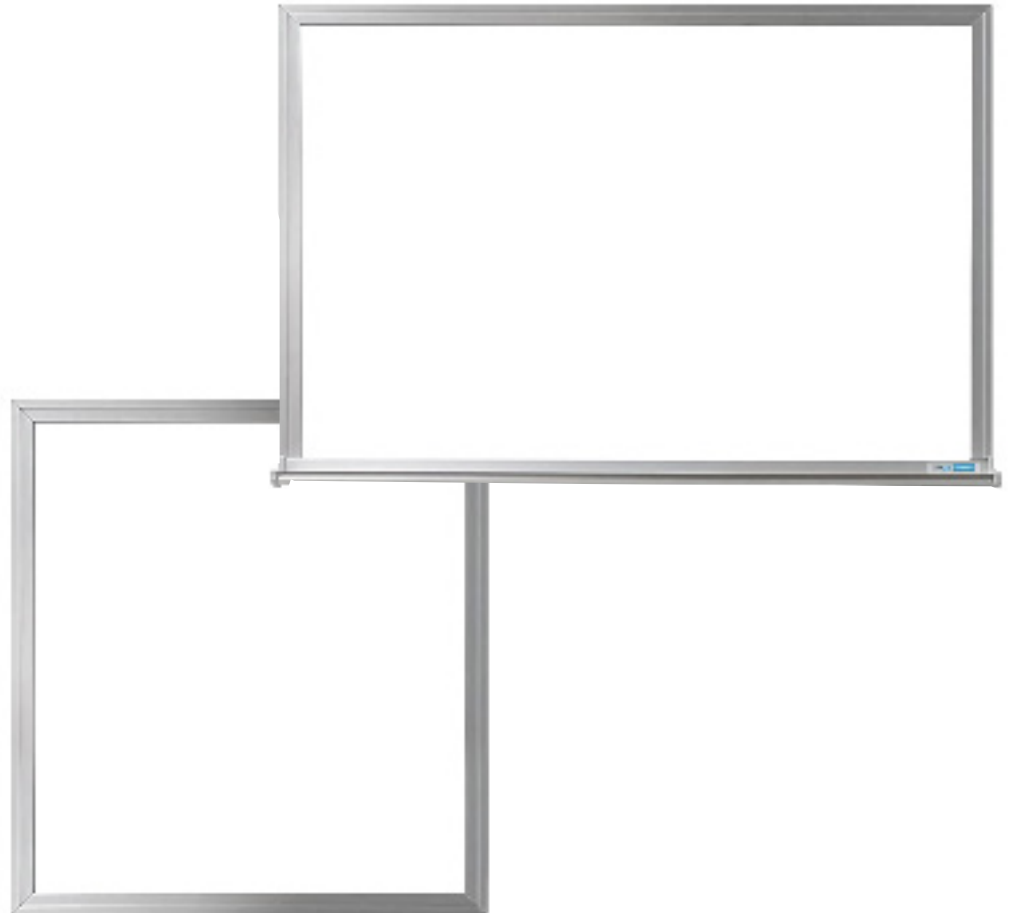

Please contact us for custom sizes or for discounted pricing on large quantities.

Wide Wood Framed Whiteboards

- Lifetime guaranteed non-staining surface
- Permanent marker resistant
- Magnetic or Non-Magnetic options available
- 1-7/8" wide solid wood frame with matching marker tray
- Whiteboard thickness is 1/2"
- Includes all mounting hardware; easy to install

Wood Finish Options

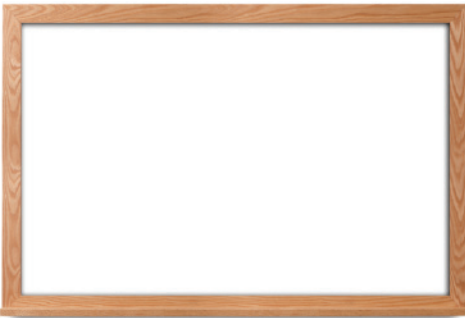

Wide Oak Frame



Wide Maple Frame



Wide Cherry Frame



Wide Mahogany Frame



Wide Black Frame

Oak/Maple/Black/ Cherry/Mahogany Framed Magnetic Whiteboards

Size (HxW)

- 1' x 1'
- 1.5' x 2'
- 2' x 2'
- 2' x 3'
- 2' x 4'
- 3' x 4'
- 4' x 4'
- 4' x 5'
- 4' x 6'
- 4' x 8'
- 4' x 10'
- 4' x 12'
- 4' x 16'
- 4' x 20'

Oak/Maple/Black/ Cherry/Mahogany Framed Non-Magnetic Whiteboards

Size (HxW)

- 1' x 1'
- 1.5' x 2'
- 2' x 2'
- 2' x 3'
- 2' x 4'
- 3' x 4'
- 4' x 4'
- 4' x 5'
- 4' x 6'
- 4' x 8'

Please contact us for custom sizes or for discounted pricing on large quantities.

Narrow Wood Framed Whiteboards

- Lifetime guaranteed non-staining surface
- Permanent marker resistant
- Magnetic or Non-Magnetic options available
- 1-1/4" wide solid wood frame with matching marker tray
- Whiteboard thickness is 1/2"
- Includes all mounting hardware; easy to install

Wood Finish Options



Narrow Oak Frame



Narrow Maple Frame



Narrow Cherry Frame



Narrow Mahogany Frame



Narrow Black Frame

Oak/Maple/Black/
Cherry/Mahogany Framed
Magnetic & Non-Magnetic
Whiteboards

Size (HxW)

1' x 1'

1.5' x 2'

2' x 2'

2' x 3'

2' x 4'

3' x 4'

4' x 4'

4' x 5'

4' x 6'

Please contact us for custom sizes or for discounted pricing on large quantities.

ULTImatte 5-Foot Tall Matte Projection Whiteboards

- Low-glare surface is ideal for use as a projection whiteboard
- 5-foot height gives 20% more space than standard 4-foot high whiteboards
- Lifetime guaranteed non-staining, non-porous surface
- Permanent marker resistant
- Magnetic
- 5/8" narrow aluminum frame (1-1/8" wide available upon request)
- Aluminum marker tray with no-snag end caps option available at no extra cost
- Whiteboard thickness is 1/2"
- Includes all mounting hardware; easy to install



All boards larger than 5'x12' are manufactured as multiple pieces of equal size with an H-channel seam (shown below) in the middle, unless otherwise specified.

ULTImatte Projection Whiteboards (M7600)

Size (HxW)

5' x 6'

5' x 8'

5' x 10'

5' x 12'



Please contact us for custom sizes or for discounted pricing on large quantities.

Plain Mobile Whiteboards

- Best erasability of any whiteboard, easiest to clean and surface stays bright and white
- Lifetime guaranteed non-staining, non-porous surface
- Permanent marker resistant
- Magnetic on both sides
- Aluminum frame with full-width, double sided marker tray
- Locking mechanisms allow board to be positioned securely at any angle
- Casters are 3" in diameter and 13/16" wide, with a non-marking rubber tread



EDISON *Series*

Idea Boards



Mobile Plain Double-Sided Whiteboard (L7M00)

Size (HxW)

- 36" x 24"
- 36" x 48"
- 40" x 29"
- 48" x 72"
- 48" x 96"



Plain White
L7M00



Locking mechanism

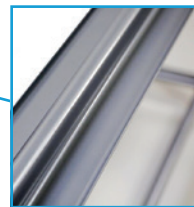

Double sided marker tray

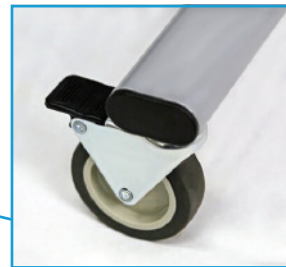

Non-marking casters

Please contact us for custom sizes or for discounted pricing on large quantities.

Printed Mobile Whiteboards

- Best erasability of any whiteboard, easiest to clean and surface stays bright and white
- Lifetime guaranteed non-staining, non-porous surface
- Permanent marker resistant
- Magnetic on both sides
- Aluminum frame with full-width, double sided marker tray
- Locking mechanisms allow board to be positioned securely at any angle
- Casters are 3" in diameter and 13/16" wide, with a non-marking rubber tread

EDISON *Series*
Idea Boards

Board Dimensions

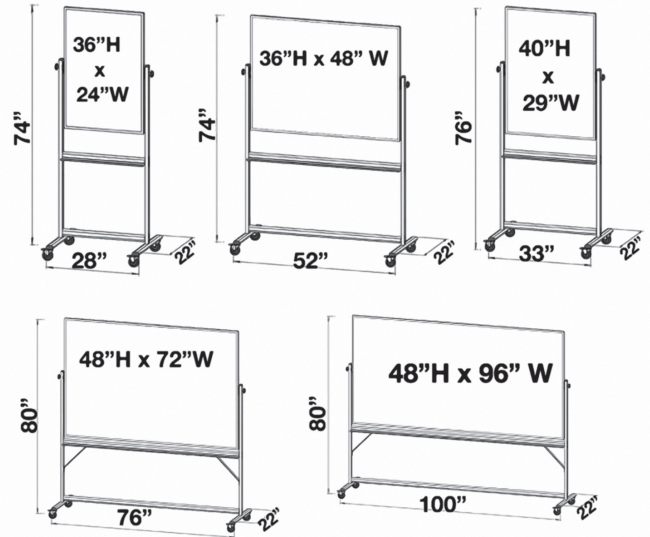

Mobile Standard Print Double-Sided (Graphic/Graphic) Whiteboard

Size (HxW)

36" x 24"

36" x 48"

40" x 29"

48" x 72"

48" x 96"

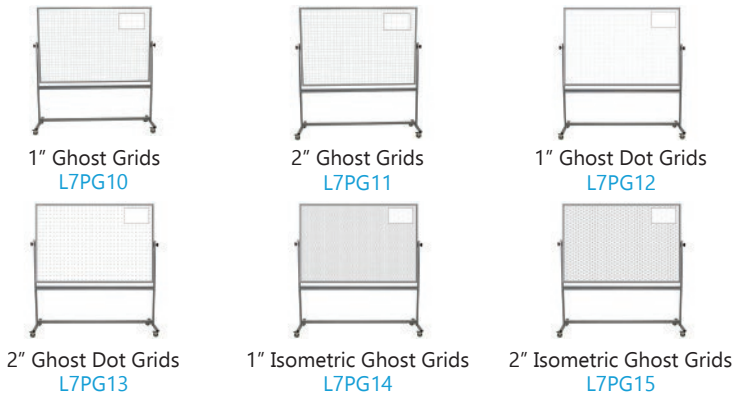

Mobile Standard Print Double-Sided (Graphic/White) Whiteboard

Size (HxW)

36" x 24"

36" x 48"

40" x 29"

48" x 72"

48" x 96"

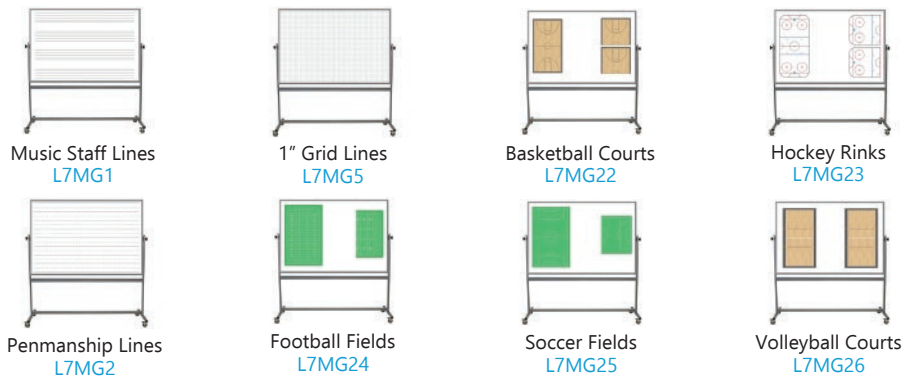

Please contact us for custom sizes or for discounted pricing on large quantities.

Education Printed Whiteboards

- Graphics are embedded under the easy to clean dry erase surface that stays bright and white
- Lifetime guaranteed non-staining, non-porous surface
- Permanent marker resistant
- Magnetic or Non-Magnetic options available
- 5/8" narrow aluminum frame (1-1/8" wide available upon request)
- Aluminum marker tray with no-snap end caps option available at no extra cost
- Whiteboard thickness is 1/2"
- Includes all mounting hardware; easy to install



Graphic Options

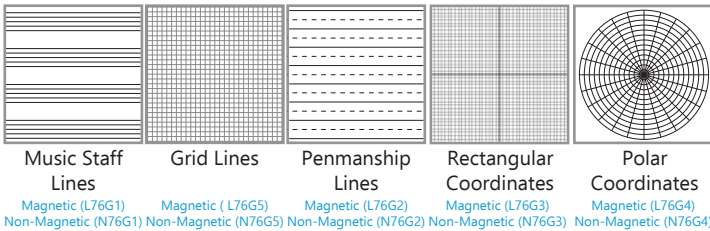

Graphic Configurations

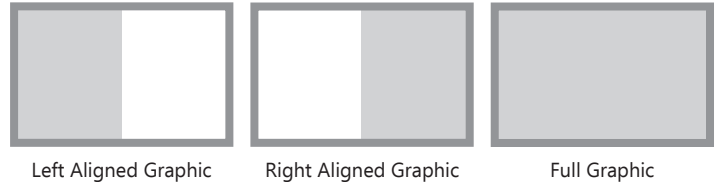

Grid Lines, Rectangular Coordinates and Polar Coordinates printed whiteboards start at size 4' x 4'

Magnetic Education Printed Whiteboard

Size (HxW)

1' x 1'

1.5' x 2'

2' x 2'

2' x 3'

2' x 4'

3' x 4'

4' x 4'

4' x 5'

4' x 6'

4' x 8'

4' x 10'

4' x 12'

4' x 16'

4' x 20'

Non-Magnetic Education Printed Whiteboard

Size (HxW)

1' x 1'

1.5' x 2'

2' x 2'

2' x 3'

2' x 4'

3' x 4'

4' x 4'

4' x 5'

4' x 6'

4' x 8'

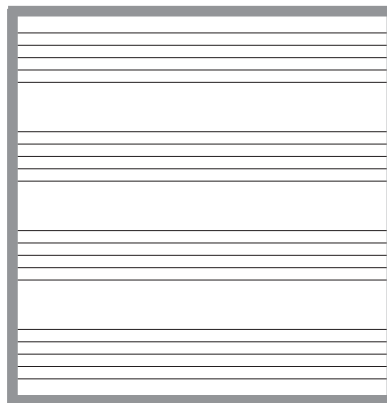

(L76G1)

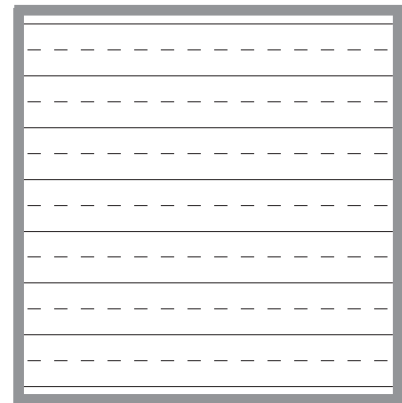

(L76G2)

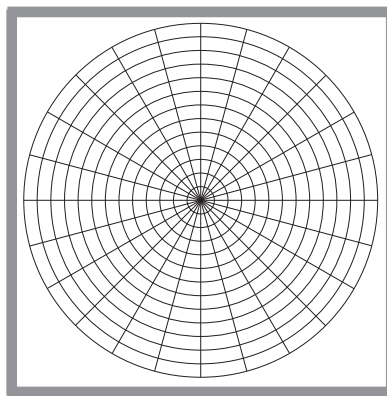

(L76G4)

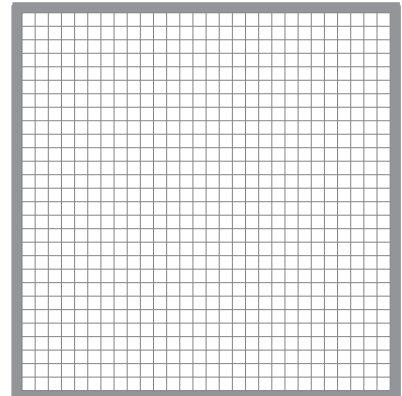

(L76G5)

Please contact us for custom sizes or for discounted pricing on large quantities.

EZGrid Ghost Whiteboards

- Graphics are embedded under the easy to clean dry erase surface that stays bright and white
- Lifetime guaranteed non-staining, non-porous surface
- Permanent marker resistant
- Magnetic or Non-Magnetic options available
- 5/8" narrow aluminum frame (1-1/8" wide available upon request)
- Aluminum marker tray with no-snag end caps option available at no extra cost
- Whiteboard thickness is 1/2"
- Includes all mounting hardware; easy to install

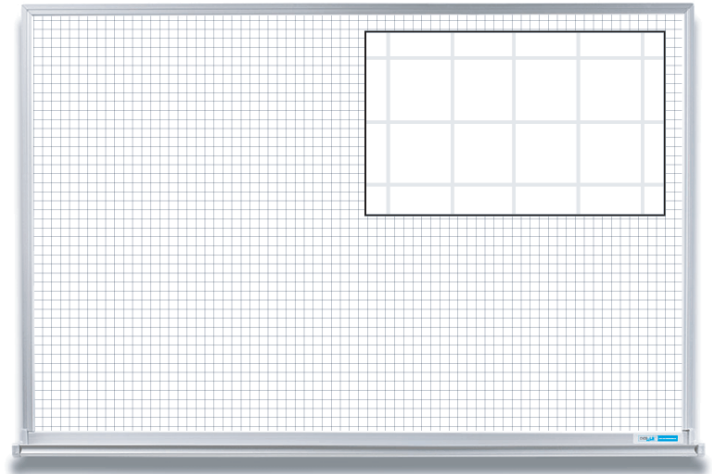

1" Ghost Dots

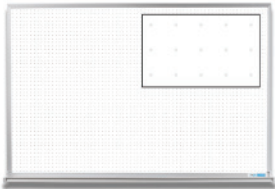

1" Ghost Dots
Magnetic (L76G12)
Non-Magnetic (N76G18)

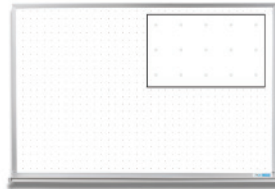

2" Ghost Dots
Magnetic (L76G13)
Non-Magnetic (N76G19)

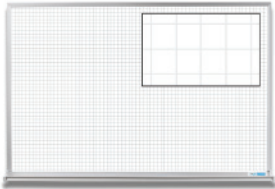

1" Ghost Grid
Magnetic (L76G10)
Non-Magnetic (N76G16)

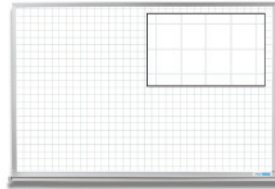

2" Ghost Grid
Magnetic (L76G11)
Non-Magnetic (N76G17)



1" Isometric Ghost Grid
Magnetic (L76G14)
Non-Magnetic (N76G20)

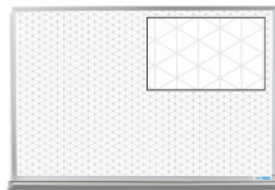

2" Isometric Ghost Grid
Magnetic (L76G15)
Non-Magnetic (N76G21)



1" Ghost Grids
L7PG10



2" Ghost Grids
L7PG11



1" Ghost Dot Grids
L7PG12



2" Ghost Dot Grids
L7PG13



1" Isometric Ghost Grids
L7PG14



2" Isometric Ghost Grids
L7PG15

EZGrid Ghost Magnetic Whiteboard or Mobile Whiteboard

Size (HxW)

2' x 3'

3' x 4'

4' x 4'

4' x 6'

4' x 8'

4' x 10'

4' x 12'

EZGrid Ghost Non-Magnetic Whiteboard or Mobile Whiteboard

Size (HxW)

2' x 3'

3' x 4'

4' x 4'

4' x 6'

4' x 8'

*See page 19 for pricing and more information on Ghost Grid Mobile Boards

Please contact us for custom sizes or for discounted pricing on large quantities.

Calendar Whiteboards

- Graphics are embedded under the easy to clean dry erase surface that stays bright and white
- Lifetime guaranteed non-staining, non-porous surface
- Permanent marker resistant
- Magnetic or Non-Magnetic options available
- 5/8" narrow aluminum frame (1-1/8" wide available upon request)
- Aluminum marker tray with no-snap end caps option available at no extra cost
- Whiteboard thickness is 1/2"
- Includes all mounting hardware; easy to install
- Available colors are Black and White, Gray, Beige and Blue
- Month and date magnet accessories are available as an additional purchase (shown right)



1-Month and 2-Month Calendar Magnetic/Non-Magnetic Whiteboard

Size (HxW)

2' x 3'

3' x 4'

4' x 6'

3-Month Calendar Magnetic/Non-Magnetic Whiteboard

Size (HxW)

3' x 4'

4' x 6'

4' x 8'

4-Month Calendar Magnetic/Non-Magnetic Whiteboard

Size (HxW)

3' x 4'

4' x 4'

4' x 6'

4' x 8'

6-Month and 12-Month Calendar Magnetic/Non-Magnetic Whiteboard

Size (HxW)

4' x 6'

4' x 8'

Available Colors



Black and White

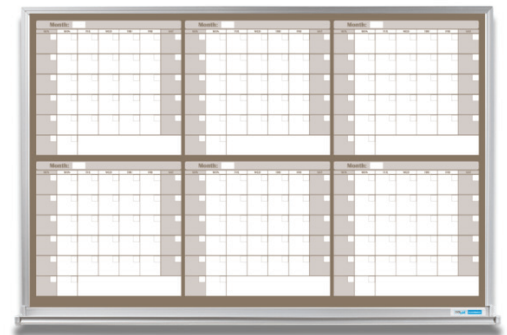

Beige

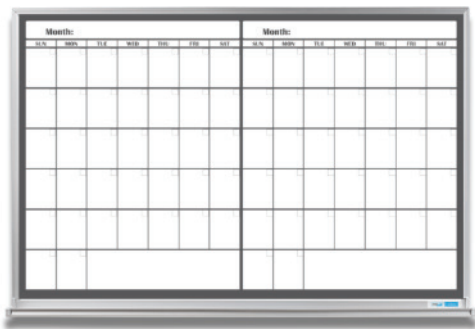

Gray

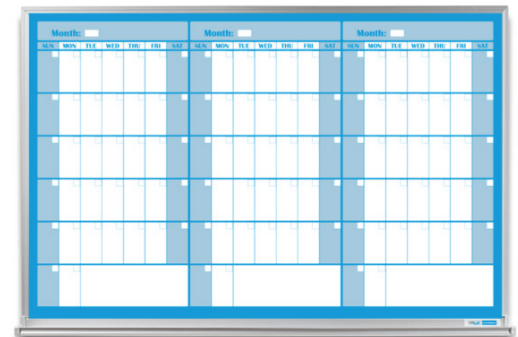

Blue

Please contact us for custom sizes or for discounted pricing on large quantities.

Coaching Whiteboards

- Graphics are embedded under the easy to clean dry erase surface that stays bright and white
- Lifetime guaranteed non-staining, non-porous surface
- Permanent marker resistant
- Magnetic or Non-Magnetic options available
- 5/8" narrow aluminum frame (1-1/8" wide available upon request)
- Aluminum marker tray with no-snap end caps option available at no extra cost
- Whiteboard thickness is 1/2"
- Includes all mounting hardware; easy to install

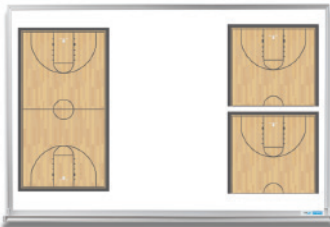

Basketball Courts
 Magnetic (L76G22)
 Non-Magnetic (N76G27)

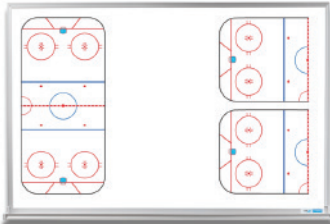

Hockey Rinks
 Magnetic (L76G23)
 Non-Magnetic (N76G28)

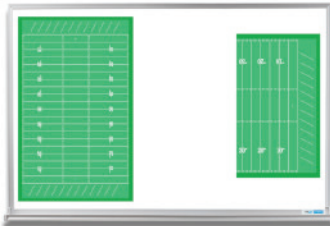

Football Fields
 Magnetic (L76G24)
 Non-Magnetic (N76G29)



Soccer Fields
 Magnetic (L76G25)
 Non-Magnetic (N76G30)

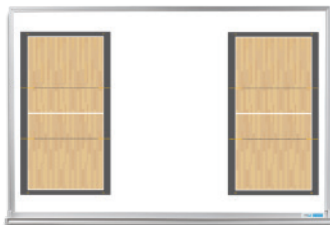

Volleyball Courts
 Magnetic (L76G26)
 Non-Magnetic (N76G31)

Coaching Magnetic/ Non-Magnetic Whiteboard

Size (HxW)

3' x 4'

4' x 6'

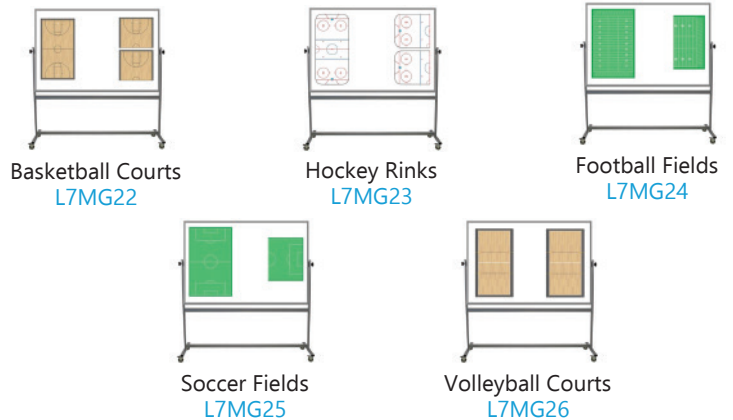

*See page 19 for pricing and more information on Mobile Coaching Boards

Please contact us for custom sizes or for discounted pricing on large quantities.

Custom Printed Whiteboards

- Custom print your Whiteboard, Mobile Board, Resurfacing Panel or Magnetic Overlay
- Graphics are embedded under the easy to clean dry erase surface that stays bright and white
- Lifetime guaranteed non-staining, non-porous surface
- Permanent marker resistant
- Fully customizable to your needs
- Design yourself or let our graphics team work with you!

**ANY IDEA
ANY DESIGN
ANY WORDING
WE CAN DO THAT!**

Why Custom Print a Whiteboard?

- Heighten efficiency and organization
- Increase visibility of important information
- Present an eye-catching visual display

Customization is our specialty! EVERWhite offers many standard and custom framing options, and we're happy to work with you on customizing your dry erase surface to achieve the look you desire.

The possibilities for EVERWhite's custom printed whiteboards are endless. Examples of common applications include:

Manufacturing and Production

- Scheduling
- Production
- Lean Manufacturing
- Quality Control
- Materials/Inventory
- Safety

Healthcare

- Patient Charts
- Nurses' Stations
- Operating Rooms
- Care Facilities

Corporate

- Brand Identity
- Sales Goals
- Calendars
- Project Management

Restaurants/Bars and Hospitality

- Daily Specials or Menus
- Staffing
- Events
- Brand Identity

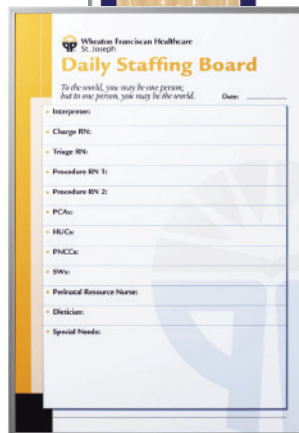
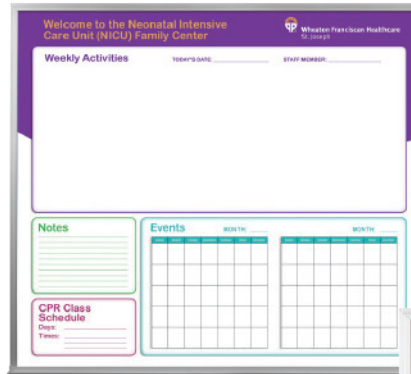

Please contact us for custom sizes or for discounted pricing on large quantities.

Custom Printed Gallery

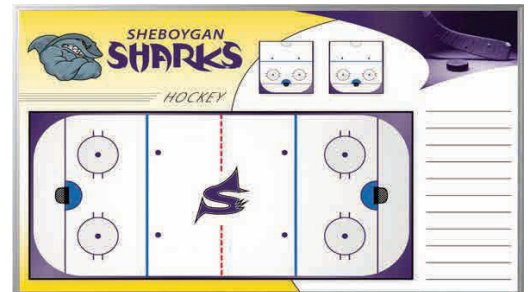
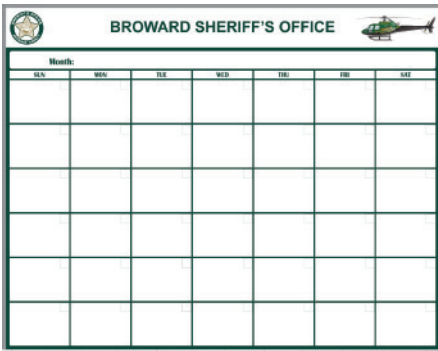
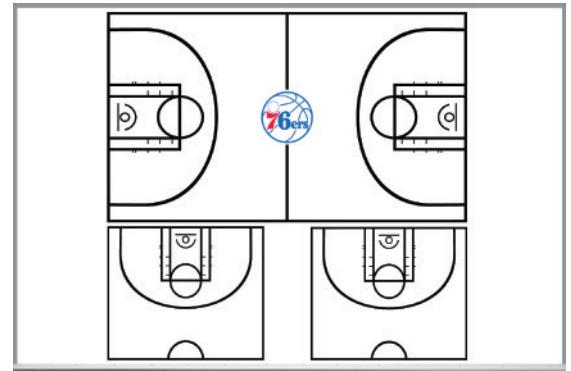

GRAPHIC READY FOR PRINT	DESIGN PARTIALLY COMPLETED	DESIGN IDEA OR SKETCH ONLY
\$75.00 per design	\$125.00 per design	\$185.00 per design
I have a completed design for my whiteboard and have a high-quality graphic file sized correctly.	I have high-quality graphic elements but need help creating the final design.	I have a sketch or drawing of my graphic idea but need help in creating a custom design.

Please contact us for custom sizes or for discounted pricing on large quantities.

Custom Printed Whiteboards

Custom Print Aluminum Framed Magnetic Whiteboard

Size (HxW)

- 1' x 1'
- 1.5' x 2'
- 2' x 2'
- 2' x 3'
- 2' x 4'
- 3' x 4'
- 4' x 4'
- 4' x 5'
- 4' x 6'
- 4' x 8'
- 4' x 10'
- 4' x 12'
- 4' x 16'
- 4' x 20'

Custom Print Aluminum Framed Non-Magnetic Whiteboard

Size (HxW)

- 1' x 1'
- 1.5' x 2'
- 2' x 2'
- 2' x 3'
- 2' x 4'
- 3' x 4'
- 4' x 4'
- 4' x 5'
- 4' x 6'
- 4' x 8'

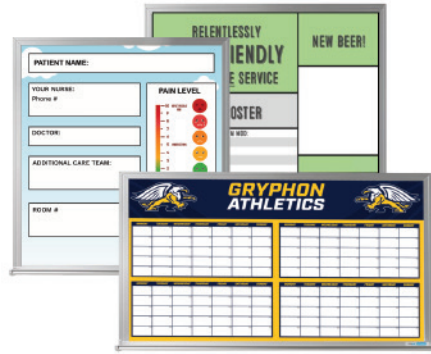

Custom Print Magnetic Resurfacing Panel

Size (HxW)

- 1' x 1'
- 1.5' x 2'
- 2' x 2'
- 2' x 3'
- 2' x 4'
- 3' x 4'
- 4' x 4'
- 4' x 5'
- 4' x 6'
- 4' x 8'
- 4' x 10'
- 4' x 12'
- 4' x 16'
- 4' x 20'
- 4' x 24'



Mobile Custom Print Double-Sided (Graphic/White) Whiteboard - Double-Sided Graphics Available Upon Request

Size (HxW)

- 36" x 24"
- 36" x 48"
- 40" x 29"
- 48" x 72"
- 48" x 96"



Artwork Fees

GRAPHIC READY FOR PRINT	DESIGN PARTIALLY COMPLETED	DESIGN IDEA OR SKETCH ONLY
\$75.00 per design	\$125.00 per design	\$185.00 per design
I have a completed design for my whiteboard and have a high-quality graphic file sized correctly.	I have high-quality graphic elements but need help creating the final design.	I have a sketch or drawing of my graphic idea but need help in creating a custom design.

Please contact us for custom sizes or for discounted pricing on large quantities.

Custom Printed Magnetic Overlays

- Graphics are embedded under the easy to clean dry erase surface that stays bright and white
- Lifetime guaranteed non-staining surface
- Permanent marker resistant
- For use with magnetic dry erase surfaces
- Overall thickness of 0.30"
- Ships rolled up in a tube

Please note, sizes 12" x 24" through 24" x 72" are for wall-mounted boards. Sizes 45.75" x 24" through 45.75" x 96" are for mobile whiteboards.

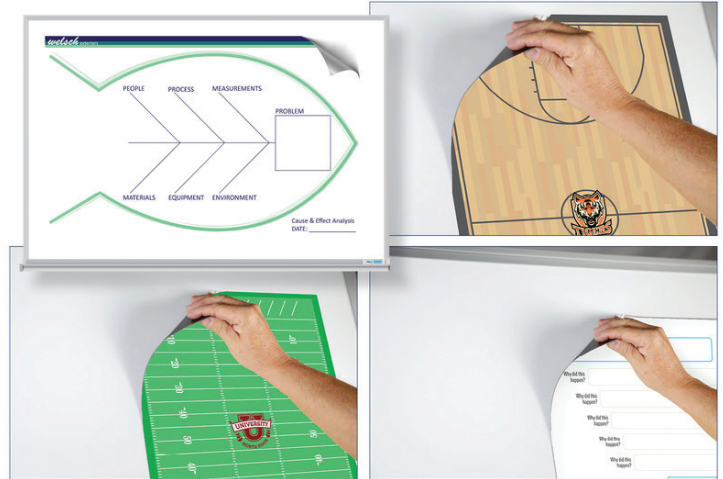

Custom Printed Magnetic Overlay

Size (HxW)

12" x 24"

18" x 24"

24" x 12"

24" x 24"

24" x 36"

24" x 48"

24" x 60"

24" x 72"

45.75" x 24"

45.75" x 45.75"

45.75" x 48"

45.75" x 60"

45.75" x 72"

45.75" x 96"

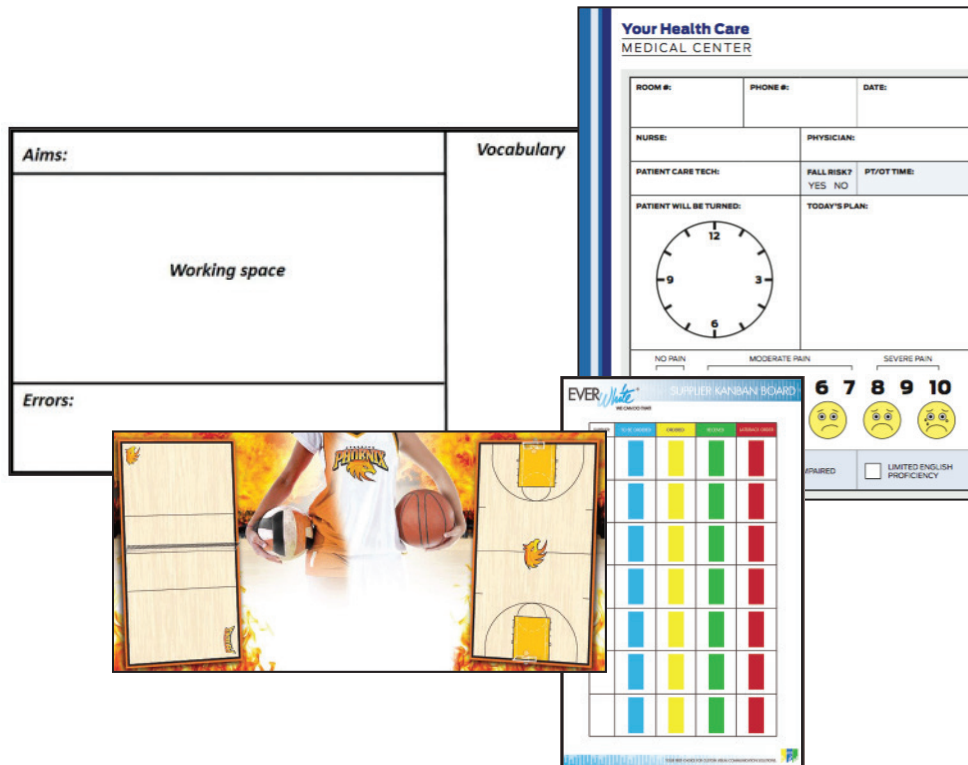

Artwork Fees

GRAPHIC READY FOR PRINT	DESIGN PARTIALLY COMPLETED	DESIGN IDEA OR SKETCH ONLY
\$75.00 per design	\$125.00 per design	\$185.00 per design
I have a completed design for my whiteboard and have a high-quality graphic file sized correctly.	I have high-quality graphic elements but need help creating the final design.	I have a sketch or drawing of my graphic idea but need help in creating a custom design.

Please contact us for custom sizes or for discounted pricing on large quantities.

Re-Stic Removable

Re-Stic Dry Erase Surfaces

Our Re-Stic Dry Erase Surface is perfect for use on any wall, door, desk or table - the applications are endless! This flexible whiteboard can easily be cut to fit the surface of your choice, equipping you with the ability to brainstorm anywhere, anytime. Instantly peel and stick to your desired surface. Our specially formulated self stick adhesive technology is repositionable and always removable, making it safe for walls with no stick residue left behind. Everase's Re-Stic line offers the same proven proprietary dry erase technology and superior writing surface as our dry erase products that have been used in schools across the USA. Make Re-Stic your Dry Erase Solution.

Features & Benefits:

- Brainstorm, collaborate and communicate! Perfect for any wall, door or desk
- No tools required - just peel and stick
- Removable and repositionable. No sticky residue left behind!
- Can be cut to any size

Applications:

- Home
- Office
- School
- Hospitality
- Point of Purchase
- And more!



Plain White

Name	Item #	Size	Weight	Package Dimensions
Re-Stic Dry Erase Surface - White, 1 x 1.5 ft.	FA11NE-12x18	1 x 1.5 ft.	0.69 lbs	18.5" x 0.25" x 14.25"
Re-Stic Dry Erase Surface - White, 2 x 3 ft.	FA11NE-24x36	2 x 3 ft.	0.94 lbs	25.5" x 3.25" x 3.25"
Re-Stic Dry Erase Surface - White, 3 x 4 ft.	FA11NE-36x48	3 x 4 ft.	1.69 lbs	37.5" x 3.25" x 3.25"
Re-Stic Dry Erase Surface - White, 4 x 6 ft.	FA11NE-48x72	4 x 6 ft.	3.65 lbs.	52.5" x 4.25" x 4.25"
Re-Stic Dry Erase Surface - White, 4 x 8 ft.	FA11NE-48x96	4 x 8 ft.	4.12 lbs	52.5" x 4.25" x 4.25"

Plain White Dry Erase Sheets

Name	Item #	Size	Weight	Package Dimensions
Re-Stic Dry Erase Surface - Dry Erase Sheets, 6 x 8 in. (15 Sheets)	FA11NE-6x8-15	6 x 8	0.50 lbs	9" x 0.25" x 7"
Re-Stic Dry Erase Surface - Dry Erase Sheets, 9 x 12 in. (15 Sheets)	FA11NE-9x12-15	9 x 12	1.25 lbs	13.5" x 0.25" x 11"
Re-Stic Dry Erase Surface - Dry Erase Sheets, 12 x 18 in. (15 Sheets)	FA11NE-12x18-15	12 x 18	2.25 lbs	18.5" x 0.25" x 14.25"

Get the chalkboard look without the mess of any chalk dust! Great with fluorescent/neon/wet erase markers and can be removed with minimal effort and no stains or ghosting left behind - guaranteed!



Plain Black

Name	Item #	Size	Weight	Package Dimensions
Re-Stic Dry Erase Surface - Black, 1 x 1.5 ft.	FC111NE-12x18	1 x 1.5 ft.	0.69 lbs	18.5" x 0.25" x 14.25"
Re-Stic Dry Erase Surface - Black, 2 x 3 ft.	FC111NE-24x36	2 x 3 ft.	0.94 lbs	25.5" x 3.25" x 3.25"
Re-Stic Dry Erase Surface - Black, 3 x 4 ft.	FC111NE-36x48	3 x 4 ft.	1.69 lbs	37.5" x 3.25" x 3.25"

Custom sizes are available upon request

Please contact us for custom sizes or for discounted pricing on large quantities.

GREAT FOR DESKS!

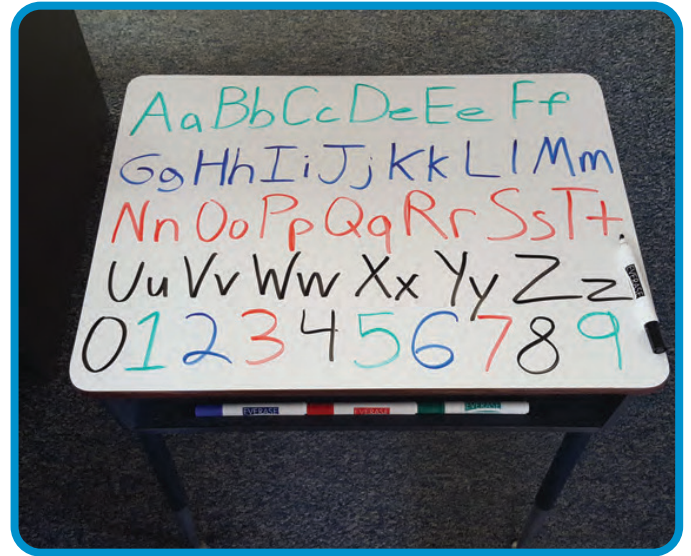

WALLS!

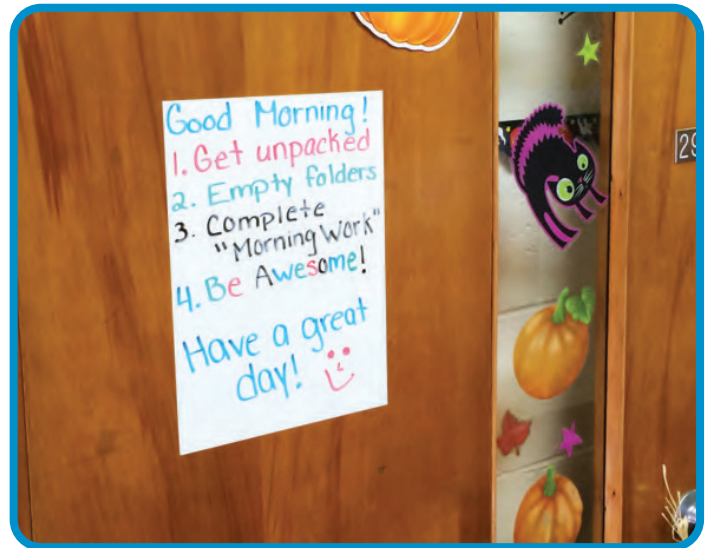

DOORS!



AND MORE!

Please contact us for custom sizes or for discounted pricing on large quantities.

Re-Stic Removable

Re-Stic offers various calendars, planners and framed board designs. Use monthly calendars to plan out each month and weekly planners to schedule every week. Planners are available in white and black dry erase designs. The black dry erase goes great with white chalk and fluorescent markers to create vibrant eye catching writing. We also carry different wood frame designs for the more traditional framed board look at a much lower price!

Applications:

- Walls
- Desks
- Doors
- Refrigerators
- and More!



Features & Benefits:

- Vibrant, digital quality images and colors
- Digital print embedded under dry erase surface
- Stay organized by keeping track of your monthly and weekly schedules
- No tools required - just peel and stick
- Removable and repositionable. No sticky residue left behind!
- FREE Marker and cloth included!

Re-Stic Standard Printed

Name	Item #	Size	Weight	Package Dimensions
Monthly Calendar, 2 x 3 ft	FA12NB-24x36	2 x 3 ft.	1.07 lbs.	25.5" x 3.25" x 3.25"
Weekly Planner, 12 x 18 in.	FA13NB-12x18	12 x 18 in.	0.69 lbs.	18.5" x 0.25" x 14.25"
Oak Faux Frame, 2 x 3 ft.	FA14NB-24x36	2 x 3 ft.	1.07 lbs.	25.5" x 3.25" x 3.25"
Walnut Faux Frame, 2 x 3 ft.	FA15NB-24x36	2 x 3 ft.	1.07 lbs.	25.5" x 3.25" x 3.25"
Mahogany Faux Frame, 2 x 3 ft.	FA16NB-24x36	2 x 3 ft.	1.07 lbs.	25.5" x 3.25" x 3.25"
Monthly Planner, 12 x 16 in.	FA17NB-12x16	12 x 16 in.	0.69 lbs.	18.5" x 0.25" x 14.25"
Blackboard Monthly Planner, 12 x 16 in	FA18NB-12x16	12 x 16 in.	0.69 lbs.	18.5" x 0.25" x 14.25"
Meal Planner, 12 x 16 in.	FA19NB-12x16	12 x 16 in.	0.69 lbs.	18.5" x 0.25" x 14.25"
Blackboard Meal Planner, 12 x 16 in.	FA110NB-12x16	12 x 16 in.	0.69 lbs.	18.5" x 0.25" x 14.25"
Annual Calendar, 3 x 4 ft.	FC112NB-36x48	3 x 4 ft.	1.60 lbs.	37.5" x 3.25" x 3.25"
4 Month Planner, 2 x 3 ft.	FC113NB-24x36	2 x 3 ft.	1.07 lbs.	25.5" x 3.25" x 3.25"
Babysitter Planner, 12 x 16 in.	FC114NB-12x16	12 x 16 in.	0.69 lbs.	18.5" x 0.25" x 14.25"
Sticky Notes, 12 x 18 in.	FC115NB-12x18	12 x 18 in.	0.69 lbs.	18.5" x 0.25" x 14.25"
Speech Bubbles, 12 x 18 in.	FC116NB-12x18	12 x 18 in.	0.69 lbs.	18.5" x 0.25" x 14.25"
Thought Bubbles, 12 x 18 in.	FC117NB-12x18	12 x 18 in.	0.69 lbs.	18.5" x 0.25" x 14.25"
Clipboard, 9 x 12 in.	FC118NB-9x12	9 x 12 in.	0.40 lbs.	13.5" x 0.25" x 11"
Notepad, 9 x 12 in.	FC119NB-9x12	9 x 12 in.	0.40 lbs.	13.5" x 0.25" x 11"

Please contact us for custom sizes or for discounted pricing on large quantities.

Re-Stic Printed Organizers

Re-Stic Removable

FA12NB-24x36: Monthly Calendar

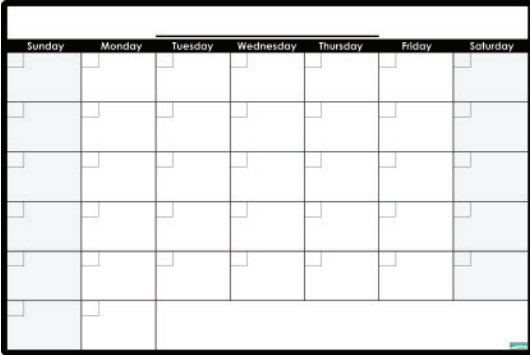

FA13NB-12x18: Weekly Planner

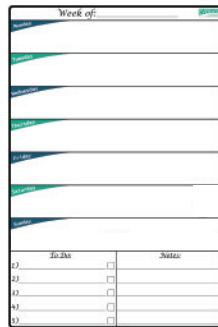

FA14NB-24x36: Oak



FA15NB-24x36: Walnut



FA16NB-24x36: Mahogany



FA17NB-12x16: Monthly Planner

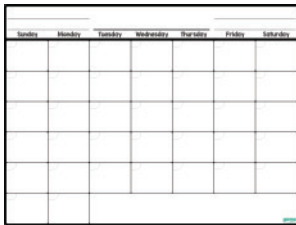

FA18NB-12x16: Blackboard Monthly Planner

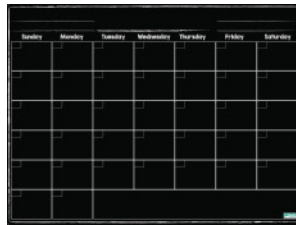

FA19NB-12x16: Meal Planner



FA110NB-12x16: Blackboard Meal Planner



FC112NB-36x48: Annual Calendar

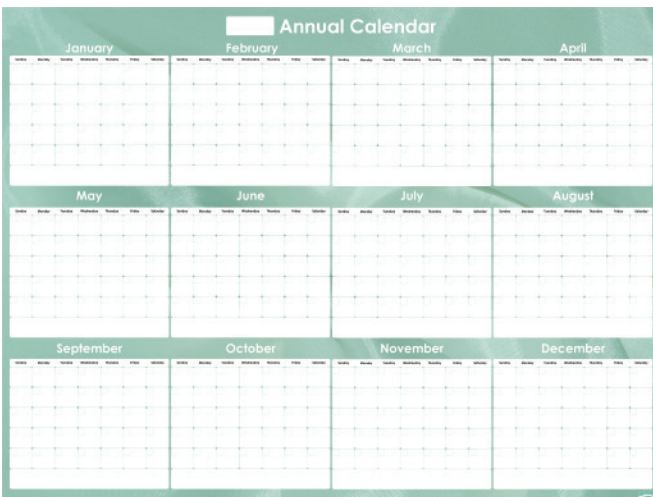

FC113NB-24x36: 4 Month Planner



FC114NB-12x16 Babysitter Planner



FC115NB-12x18: Sticky Notes

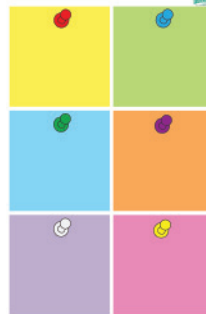

FC116NB-12x18: Speech Bubbles



FC117NB-12x18: Thought Bubbles



FC118NB-9x12: Clipboard



FC119NB-9x12: Notepad



Standard Dry Erase Products Include:
 1 Eraser Cloth
 1 Dry Erase Marker
 w/ Eraser tip, magnet & hanging clip



Blackboard Dry Erase Products Include:
 1 Eraser Cloth
 1 Liquid Chalk Marker
 w/ hanging clip



PEEL STICK WRITE ERASE REMOVE

Please contact us for custom sizes or for discounted pricing on large quantities.

Custom Printed Re-Stic

Custom Printed Re-Stic Dry Erase Surfaces are perfect for use on any wall, door, desk or table – the applications are endless! EVERWhite can print custom Re-Stic Dry Erase sheets with logos, graphics, and designs of your choice, from team mascots to family photos. If you can imagine it, we can create it!

Specifications:

- Custom printed design to suit your needs. Artwork fees apply.
- Various standard sizes: 9"x12", 11"x17", 18"x24", 2'x2', 2'x3', 3'x4', 3'x3', 3'x4', 3'x5', 4'x4', 4'x5', 4'x6', 4'x7', and 4'x8'.
- Custom sizes available! Ask for a quote.

Features & Benefits:

- Vibrant, digital quality images and colors of your choice
- Custom digital print embedded under dry erase surface
- No tools required - just peel and stick
- Removable and repositionable. No sticky residue left behind!
- Doesn't damage walls or furniture

Re-Stic Custom Printed

Item #	Size
FA10NB9x12	9 x 12 in.
FA10NB11x17	11 x 17 in. (3 qty. minimum)
FA10NB18x24	18 x 24 in. (2 qty. minimum)
FA10NB24x24	2 x 2 ft.
FA10NB24x36	2 x 3 ft.
FA10NB36x36	3 x 3 ft.
FA10NB36x48	3 x 4 ft.
FA10NB36x60	3 x 5 ft.
FA10NB48x48	4 x 4 ft.
FA10NB48x60	4 x 5 ft.
FA10NB48x72	4 x 6 ft.
FA10NB48x84	4 x 7 ft.
FA10NB48x96	4 x 8 ft.

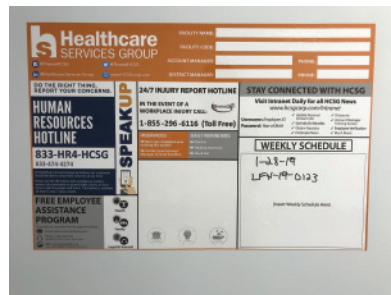

Artwork fees start at \$35.00 minimum per design for Re-Stics under 4 x 4 ft. and \$75.00 minimum per design for Re-Stics 4 x 4 ft. and larger

Please contact us for custom sizes or for discounted pricing on large quantities.

Aluminum Framed Cork Bulletin Boards

- High-density cork offers a durable, stain-resistant surface that will not crack or peel
- Crumble-resistant, self-healing cork that won't show pinholes
- Tacks can be inserted easily and are gripped firmly
- Available in 15 colors
- 5/8" narrow aluminum frame (1-1/8" wide available upon request)
- Cork board thickness is 1/2"
- Includes all mounting hardware; easy to install



Aluminum Framed Cork Bulletin Board (T7600)

Size (HxW)

- 1' x 1'
- 1.5' x 2'
- 2' x 2'
- 2' x 3'
- 2' x 4'
- 3' x 4'
- 4' x 4'
- 4' x 5'
- 4' x 6'
- 4' x 8'
- 4' x 10'
- 4' x 12'
- 4' x 16'
- 4' x 20'
- 4' x 24'

Available in 15 Sizes!

Choose from 15 Cork Colors!

T7600

 Autumn	 Charcoal	 Chili Pepper	 Cinnamon	 Clay
 Cobalt Blue	 Fog	 Grass	 Natural	 Sand
 Slate	 Stone	 Timber Wolf	 Wheat	 White Stone

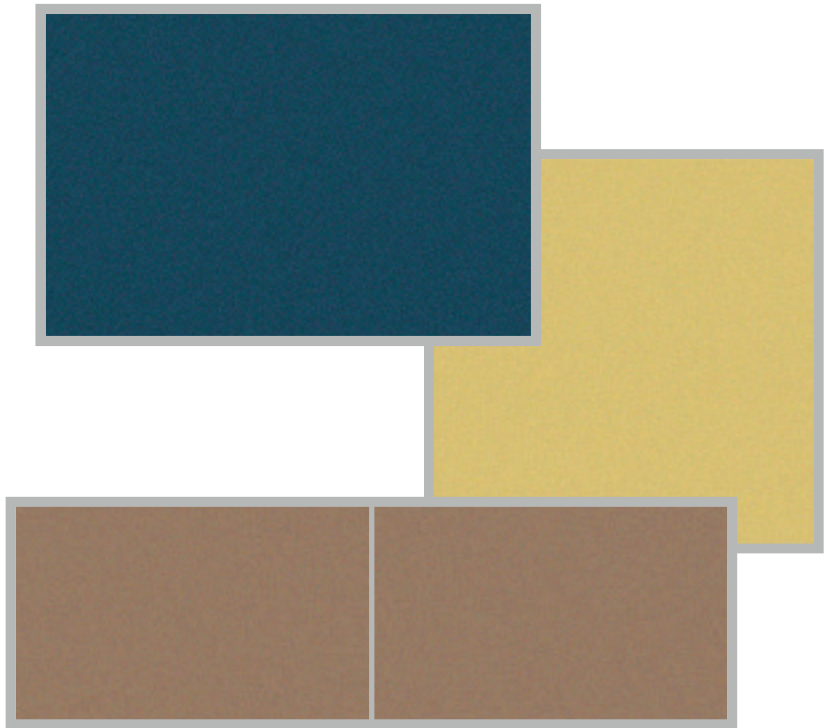

Please contact us for custom sizes or for discounted pricing on large quantities.

Wood Framed Cork Bulletin Boards

- High-density cork offers a durable, stain-resistant surface that will not crack or peel
- Crumble-resistant, self-healing cork that won't show pinholes
- Tacks can be inserted easily and are gripped firmly
- Available in 15 colors
- 1-1/4" narrow or 1-7/8" wide solid wood frame

Wood Finish Options



Oak/Maple/Cherry/Mahogany/Black Narrow Framed Cork Bulletin Board

Size (HxW)

1' x 1'

1.5' x 2'

2' x 2'

2' x 3'

2' x 4'

3' x 4'

4' x 4'

4' x 5'

4' x 6'

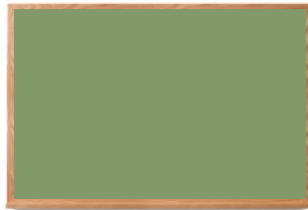

Narrow Oak Frame



Narrow Cherry Frame



Narrow Maple Frame

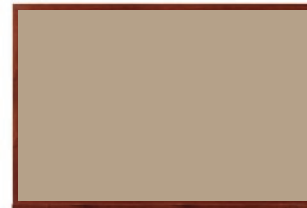

Narrow Mahogany Frame



Narrow Black Frame

Oak/Maple/Cherry/Mahogany/Black Wide Framed Cork Bulletin Board

Size (HxW)

1' x 1'

1.5' x 2'

2' x 2'

2' x 3'

2' x 4'

3' x 4'

4' x 4'

4' x 5'

4' x 6'

4' x 8'

4' x 10'

4' x 12'

4' x 16'

4' x 20'

4' x 24'

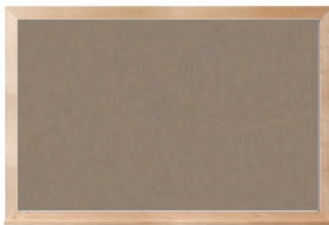

Wide Oak Frame



Wide Cherry Frame



Wide Maple Frame

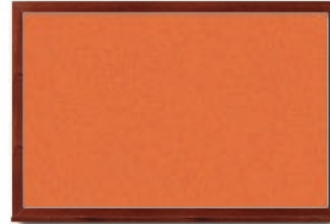

Wide Mahogany

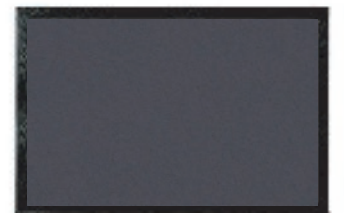

Wide Black Frame

Please contact us for custom sizes or for discounted pricing on large quantities.

Aluminum Combination Dry Erase and Cork Boards - Magnetic and Non-Magnetic

- Combination of lifetime guaranteed, non-staining dry erase surface and self-healing, high-density cork
- Four (4) combination styles to choose from
- Magnetic or Non-Magnetic options available
- Cork is available in 15 colors
- 5/8" narrow aluminum frame (1-1/8" Wide available upon request)
- Board thickness is 1/2"
- Includes all mounting hardware; easy to install



Aluminum Framed Combo Board Style A and C

Size (HxW)

4' x 4'

4' x 6'

4' x 8'

4' x 10'

4' x 12'



Aluminum Framed Combo Board Style B and D

Size (HxW)

4' x 8'

4' x 10'

4' x 12'

4' x 16'

Please contact us for custom sizes or for discounted pricing on large quantities.

Wood Combination Dry Erase and Cork Boards - Magnetic and Non-Magnetic

- 1-1/4" narrow or 1-7/8" wide solid wood frame options also available
- Crumble-resistant, self-healing cork that won't show pinholes
- Tacks can be inserted easily and are gripped firmly in cork
- Lifetime guaranteed, non-staining dry erase surface
- Optional marker tray



Aluminum Framed Magnetic Combo Board Style A

Size (HxW)

- 4' x 4'
- 4' x 6'
- 4' x 8'
- 4' x 10'
- 4' x 12'
- 4' x 16'

Aluminum Framed Magnetic Combo Board Style C

Size (HxW)

- 4' x 4'
- 4' x 6'
- 4' x 8'
- 4' x 10'
- 4' x 12'
- 4' x 16'

Aluminum Framed Non-Magnetic Combo Board Style A

Size (HxW)

- 4' x 4'
- 4' x 6'
- 4' x 8'
- 4' x 10'
- 4' x 12'

Aluminum Framed Non-Magnetic Combo Board Style C

Size (HxW)

- 4' x 4'
- 4' x 6'
- 4' x 8'



Aluminum Framed Magnetic Combo Board Style B

Size (HxW)

- 4' x 8'
- 4' x 10'
- 4' x 12'
- 4' x 16'

Aluminum Framed Magnetic Combo Board Style D

Size (HxW)

- 4' x 8'
- 4' x 10'
- 4' x 12'
- 4' x 16'

Aluminum Framed Non-Magnetic Combo Board Style B

Size (HxW)

- 4' x 8'
- 4' x 10'
- 4' x 12'
- 4' x 16'

Aluminum Framed Non-Magnetic Combo Board Style D

Size (HxW)

- 4' x 8'
- 4' x 10'
- 4' x 12'
- 4' x 16'



Wood Finish Options



Oak
Narrow (LCACA)
Wide (L72CA)



Maple
Narrow (L78CA)
Wide (L73CA)



Cherry
Narrow (L7CCA)
Wide (L77CA)



Mahogany
Narrow (L7DCA)
Wide (L78CA)



Black
Narrow (L7KCA)
Wide (L7LCA)

Narrow frames are only available up to a 4' x 6' Board

Please contact us for custom sizes or for discounted pricing on large quantities.

Accessories

Accessory Kits

Item #	Description
Starterkit	1 microfiber EVERCloth, 4 markers
Prokit	1 microfiber EVERCloth, 4 markers, 4 buttons

Whiteboard Accessories

Item #	Description
EVERCloth	A microfiber cloth eraser
EVERCloth6pk	6 microfiber cloth erasers
EVERCloth12pk	12 microfiber cloth erasers
DC	8 oz. Whiteboard cleaner
DC-CS	Case of 9 8 oz. Whiteboard cleaner
EVERmarkerset	4 low-odor dry erase markers
Magnetclip	2 clip magnets with rubber grip
Magnetbutton	5 button magnets
Endcapv2	2 plastic caps for exposed ends of aluminum marker trays
Tray Connector Grey	A plastic connector for two-piece marker trays
Seamstrip4ft	A 4' x 1/2" wide self-adhesive dry erase seam strip
H-Channel4ft	A 4' x 1/2" wide H-channel that connects two sections of board
Maprail-4	A 4' x 1" map and display rail for top mount 1/2" boards
Exhibitrail-4	A 4' cork exhibit rail for wall hanging boards
Maprail-6	A 6' x 1" map and display rail for top mount 1/2" boards
Exhibitrail-6	A 6' cork exhibit rail for wall hanging boards
Maprail-8	A 8' x 1" map and display rail for top mount 1/2" boards
Exhibitrail-8	A 8' cork exhibit rail for wall hanging boards
Maprail-10	A 10' x 1" map and display rail for top mount 1/2" boards
Maprail-12	A 12' x 1" map and display rail for top mount 1/2" boards
Maprail-flag	Flag holder for 1" map rails For flags with 1/2" diameter
Mapwinder	2 map winders for 1" map rails
Maprail-hook	2 combination hook & clip for 1" map rails



Mounting Hardware

Name	Item #	Description
6-Pack	mountkit6	Set of mounting hardware for boards 8' wide or narrower
8-Pack	mountkit8	Set of mounting hardware for boards 10' wide or wider

Month Magnet Set for Calendar Whiteboard

Name	Item #	Description
1-Month Set	CSMD1L	Set of magnets with months & dates. For 2' x 3', 3' x 4' & 4' x 6'
2-Month Set	CSMD2S	Set of magnets with months & dates. For 2' x 3' only
2-Month Set	CSMD2L	Set of magnets with months & dates. For 3' x 4' & 4' x 6' only
3-Month Set	CSMD3L	Set of magnets with months & dates. For 4' x 4', 4' x 6' & 4' x 8'
4-Month Set	CSMD4L	Set of magnets with months & dates. For 3' x 4', 4' x 4', 4' x 6' & 4' x 8'
6-Month Set	CSMD6L	Set of magnets with months & dates. For 4' x 6' & 4' x 8'
12-Month Set	CSMD12S	Set of magnets with months & dates. For 4' x 6' only
12-Month Set	CSMD12L	Set of magnets with months & dates. For 4' x 8' only

Please contact us for custom sizes or for discounted pricing on large quantities.

Testimonials

“The quality of the board is phenomenal.”

— **Jessika Kasten,**
Director of Marketing,
Wisconsin Alumni Association

“Other boards might cost less initially, but in the long run, EVERWhite boards are, by far, less costly.”

— **David Staerkel, Facilities Manager, University of Wisconsin**

“We tried three different brands of dry erase boards and found the EVERWhite boards to be far superior to the others.”

— **Darryl De Rooter,**
Principal, Pella Christian High School

“The best dry erase board we have tried.”

— **Bryan Hunter,**
Maintenance Supervisor,
Lawrence Public Schools

“Our EVERWhite dry erase board has truly added to the educational experience the students in my room have every day!”

— **Cory Greene, Teacher, Folger McKinsey Elementary**

“The quality of EVERWhite boards is first rate and only outdone by their customer service.”

— **Thomas Moore,**
Assistant Director, Indiana University Southeast

“ I always knew when ordering from EVERWhite that the quality was there, especially since EVERWhite offers a lifetime stain-free guarantee.”

— **John Beil, Director of Facilities,**
Belleville Intermediate School

Please contact us for custom sizes or for discounted pricing on large quantities.

Need Installation Services?

Professional turnkey installation services available in selected areas.

Contact us for more information and to receive a quote!





SECTION 10100
VISUAL DISPLAY BOARDS
Display hidden notes to specifier. (Don't know how? [Click Here](#))

PART 1 GENERAL

1.1 SECTION INCLUDES

- A. Visual Display Boards.
- B. Bulletin Boards.
- C. Display Board Accessories.

1.2 RELATED SECTIONS

- A. Section 06100 - Rough Carpentry: Wall Framing and Blocking.
- B. Section 05100 - Structural Metal Framing: Wall Framing and Blocking.
- C. Section 09200 - Plaster and Gypsum Board: Wall finishes prepared to receive boards.

1.3 REFERENCES

- A. ASTM E 84 - Standard Test Method for Surface Burning Characteristics for Building Materials.

1.4 SUBMITTALS

- A. A. Submit under provisions of Section 01300.
- B. Product Data: Manufacturer's data sheets on each product to be used, including:
 - 1. Preparation instructions and recommendations.
 - 2. Storage and handling requirements and recommendations.
 - 3. Installation methods.
- C. Shop Drawings: Submit manufacturer's standard drawings detailing plan and section views for each product specified.
- D. Selection Samples: For each finished product specified, complete sets of samples representing manufacturer's full range of available colors and patterns are available upon request.

1.5 QUALITY ASSURANCE

- A. Manufacturer Qualifications: All primary products specified in this section will be provided by a single manufacturer with a minimum of ten (10) years experience.

B. Regulatory Requirements: Conform to applicable code for flame/smoke ratings in bulletin boards in accordance with ASTM E84.

1.6 DELIVERY, STORAGE, AND HANDLING

A. After opening and inspecting boards for damage, return them to their original crates or cartons for storage and do not uncrate until boards are to be installed.

1. When uncrated, do not allow boards to lean at an angle against a wall or other objects, or to lie on the floor for any length of time.

2.

3. Store boards in as close to a vertical position as possible.

B. Storage and Protection: Store materials protected from exposure to harmful weather conditions and at temperature and humidity conditions recommended by manufacturer

C. Store and dispose of hazardous materials, and materials used with hazardous materials, in accordance with requirements of local authorities having jurisdiction.

1.7 PROJECT CONDITIONS

A. Maintain environmental conditions (temperature, humidity, and ventilation) within limits recommended by manufacturer for optimum results. Do not install products under environmental conditions outside manufacturer's absolute limits.

B. EverWhite products are designed to be installation-ready, however, installation and the installation environment are out of EverWhite's control and therefore installation is not warranted by EverWhite in any circumstance.

1.8 WARRANTY

A. The warranty is only valid for the original purchasing entity and covers replacement of defective product but does not include the cost of removal or reinstallation.

B. Warranty for Laminated Face Sheet: Upon request, provide to owner or owner's representative an executed copy of the Manufacturer's standard warranty in which the manufacturer agrees to repair or replace laminated face sheets that fail in material or workmanship for a period of one year from the date of purchase. Seller's sole obligation under this limited warranty would be a refund of the purchase price, subject to EverWhite's Prorated Depreciation Schedule.

C. Failures are limited to surfaces that exhibit ghosting or staining. All EverWhite dry erase surfaces are guaranteed against ghosting and staining for the lifetime of the building. Seller's sole obligation under this limited warranty would be a refund of the purchase price, subject to EverWhite's Prorated Depreciation Schedule.

PART 2 PRODUCTS

2.1 MANUFACTURERS

A. Acceptable Manufacturer: EverWhite, which is located at: 184 Railroad Drive, Warminster, PA, 18974 Toll Free Tel: 800-335-7319; Email: sales@everwhiteboards.com; Web: www.everwhiteboards.com.

B. Substitutions: Not permitted.

C. Requests for substitutions will be considered in accordance with provisions of Section 01600.

2.2 DISPLAY BOARDS

A. Magnetic Dry Erase Board: Balanced, high-pressure, factory-laminated dry erase board assembly of 3-ply construction consisting of backing sheet, core material, and a laminated 24-gauge steel face sheet with durable gloss finish highly resistant to ghosting and staining.

1. Face Sheet: Laminated 24 gauge steel sheet.
2. Color: White.
3. Core Material: 1/2 inch (12mm) thick hexacomb material.
4. Backing Sheet: 0.003 inch (0.1mm) thick manufacturer's standard moisture barrier.
5. Thickness: Nominal 1/2 inch (13mm).
6. Size: 1 foot tall by 1 foot wide (304x304mm) board.
7. Size: 1-1/2 foot tall by 2 foot wide (457x609mm) board.
8. Size: 2 foot tall by 2 foot wide (609x609mm) board.
9. Size: 2 foot tall by 3 foot wide (609x914mm) board.
10. Size: 2 foot tall by 4 foot wide (609x1219mm) board.
11. Size: 3 foot tall by 4 foot wide (914x1219mm) board.
12. Size: 4 foot tall by 4 foot wide (1219x1219mm) board.
13. Size: 4 foot tall by 5 foot wide (1219x1560mm) board.
14. Size: 4 foot tall by 6 foot wide (1219x1829mm) board.
15. Size: 4 foot tall by 8 foot wide (1219x2438mm) board.
16. Size: 4 foot tall by 10 foot wide (1219x3048mm) board.
17. Size: 4 foot tall by 12 foot wide (1219x3658mm) board.
18. Size: 4 foot tall by 16 foot wide (1219x4877mm) board.
19. Size: 4 foot tall by 20 foot wide (1219x6096mm) board.
20. Size: 4 foot tall by 24 foot wide (1219x7315mm) board.
21. Size: ___ foot tall by ___ foot wide (_____ x _____mm) board.
22. Assembly: All boards are one piece up to 12 feet (3658mm) in length. When length exceeds 12 feet (3658mm), manufacturer's H-Channel will be provided. Assembly required at site.

B. Non-Magnetic Dry Erase Board: Balanced, high-pressure, factory-laminated dry erase board assembly of 3-ply construction consisting of backing sheet, core material, and a laminated hardboard face sheet with durable gloss finish highly resistant to ghosting and staining.

1. Face Sheet: Laminated 1/8 inch (3mm) thick hardboard.
2. Color: White.
3. Core Material: 3/8 inch (9.5mm) thick hexacomb material.
4. Backing Sheet: 0.003 inch (0.1mm) thick manufacturer's standard moisture barrier.
5. Thickness: Nominal 1/2 inch (13mm).
6. Size: 1 foot tall by 1 foot wide (304x304mm) board.
7. Size: 1-1/2 foot tall by 2 foot wide (457x609mm) board.
8. Size: 2 foot tall by 2 foot wide (609x609mm) board.
9. Size: 2 foot tall by 3 foot wide (609x914mm) board.
10. Size: 2 foot tall by 4 foot wide (609x1219mm) board.
11. Size: 3 foot tall by 4 foot wide (914x1219mm) board.
12. Size: 4 foot tall by 4 foot wide (1219x1219mm) board.
13. Size: 4 foot tall by 5 foot wide (1219x1560mm) board.
14. Size: 4 foot tall by 6 foot wide (1219x1829mm) board.
15. Size: 4 foot tall by 8 foot wide (1219x2438mm) board.
16. Size: 4 foot tall by 10 foot wide (1219x3048mm) board.
17. Size: 4 foot tall by 12 foot wide (1219x3658mm) board.
18. Size: 4 foot tall by 16 foot wide (1219x4877mm) board.
19. Size: 4 foot tall by 20 foot wide (1219x6096mm) board.
20. Size: 4 foot tall by 24 foot wide (1219x7315mm) board.
21. Size: ___ foot tall by ___ foot wide (_____ x _____mm) board.
22. Assembly: All boards are one piece up to 12 feet (3658mm) in length. When length exceeds 12 feet (3658mm), manufacturer's H-Channel will be provided. Assembly required at site.

C. Laminated Steel Resurfacing Panel: A laminated steel face sheet with a durable gloss finish highly resistant to ghosting and staining.

1. Face Sheet: Laminated 24 gauge steel sheet.
2. Color: White.
3. Mounting Adhesive: Manufacturer's standard pre-applied pressure sensitive adhesive.
4. Size: 1 foot tall by 1 foot wide (304x304mm) board.
5. Size: 1-1/2 foot tall by 2 foot wide (457x609mm) board.
6. Size: 2 foot tall by 2 foot wide (609x609mm) board.
7. Size: 2 foot tall by 3 foot wide (609x914mm) board.
8. Size: 2 foot tall by 4 foot wide (609x1219mm) board.
9. Size: 3 foot tall by 4 foot wide (914x1219mm) board.
10. Size: 4 foot tall by 4 foot wide (1219x1219mm) board.
11. Size: 4 foot tall by 5 foot wide (1219x1560mm) board.
12. Size: 4 foot tall by 6 foot wide (1219x1829mm) board.
13. Size: 4 foot tall by 8 foot wide (1219x2438mm) board.
14. Size: 4 foot tall by 10 foot wide (1219x3048mm) board.
15. Size: 4 foot tall by 12 foot wide (1219x3658mm) board.
16. Size: 4 foot tall by 16 foot wide (1219x4877mm) board.
17. Size: 4 foot tall by 20 foot wide (1219x6096mm) board.
18. Size: 4 foot tall by 24 foot wide (1219x7315mm) board.
19. Size: ___ foot tall by ___ foot wide (_____ x _____mm) board.
20. Assembly: All boards are one piece up to 12 feet (3658mm) in length. When length exceeds 12 feet (3658mm), manufacturer's seam strip will be provided. Installation required at site.

D. ULTIMatte Magnetic Dry Erase Board: Balanced, high-pressure, factory-laminated dry erase board assembly of 3-ply construction consisting of backing sheet, core material, and a laminated 24-gauge steel face sheet with durable matte finish highly resistant to ghosting and staining. Can be used as a projection surface as well as a whiteboard.

1. Face Sheet: Laminated 24 gauge steel sheet.
2. Color: White.
3. Core Material: 1/2 inch (12mm) thick hexacomb material.
4. Backing Sheet: 0.003 inch (0.1mm) thick manufacturer's standard moisture barrier.
5. Thickness: Nominal 1/2 inch (13mm).
6. Size: 1 foot tall by 1 foot wide (304x304mm) board.
7. Size: 1-1/2 foot tall by 2 foot wide (457x609mm) board.
8. Size: 2 foot tall by 2 foot wide (609x609mm) board.
9. Size: 2 foot tall by 3 foot wide (609x914mm) board.
10. Size: 2 foot tall by 4 foot wide (609x1219mm) board.
11. Size: 3 foot tall by 4 foot wide (914x1219mm) board.
12. Size: 4 foot tall by 4 foot wide (1219x1219mm) board.
13. Size: 4 foot tall by 5 foot wide (1219x1560mm) board.
14. Size: 4 foot tall by 6 foot wide (1219x1829mm) board.
15. Size: 4 foot tall by 8 foot wide (1219x2438mm) board.
16. Size: 4 foot tall by 10 foot wide (1219x3048mm) board.
17. Size: 4 foot tall by 12 foot wide (1219x3658mm) board.
18. Size: 4 foot tall by 16 foot wide (1219x4877mm) board.
19. Size: 4 foot tall by 20 foot wide (1219x6096mm) board.
20. Size: 4 foot tall by 24 foot wide (1219x7315mm) board.
21. Size: 5 foot tall by 6 foot wide (1524x1829mm) board.
22. Size: 5 foot tall by 8 foot wide (1524x2438mm) board.
23. Size: 5 foot tall by 10 foot wide (1524x3048mm) board.
24. Size: 5 foot tall by 12 foot wide (1524x3658mm) board.
25. Size: ___ foot tall by ___ foot wide (_____ x _____mm) board.
26. Assembly: All boards are one piece up to 12 feet (3658mm) in length. When length exceeds 12 feet (3658mm), manufacturer's H-Channel will be provided. Assembly required at site.

E. ULTIMatte Laminated Steel Resurfacing Panel: A laminated steel face sheet with a durable matte finish highly resistant to ghosting and staining. Can be used as a projection surface as well as a whiteboard.

1. Face Sheet: Laminated 24 gauge steel sheet.
2. Color: White.
3. Mounting Adhesive: Manufacturer's standard pre-applied pressure sensitive adhesive.
4. Size: 1 foot tall by 1 foot wide (304x304mm) board.
5. Size: 1-1/2 foot tall by 2 foot wide (457x609mm) board.
6. Size: 2 foot tall by 2 foot wide (609x609mm) board.
7. Size: 2 foot tall by 3 foot wide (609x914mm) board.
8. Size: 2 foot tall by 4 foot wide (609x1219mm) board.
9. Size: 3 foot tall by 4 foot wide (914x1219mm) board.
10. Size: 4 foot tall by 4 foot wide (1219x1219mm) board.
11. Size: 4 foot tall by 5 foot wide (1219x1560mm) board.
12. Size: 4 foot tall by 6 foot wide (1219x1829mm) board.
13. Size: 4 foot tall by 8 foot wide (1219x2438mm) board.
14. Size: 4 foot tall by 10 foot wide (1219x3048mm) board.
15. Size: 4 foot tall by 12 foot wide (1219x3658mm) board.
16. Size: 4 foot tall by 16 foot wide (1219x4877mm) board.
17. Size: 4 foot tall by 20 foot wide (1219x6096mm) board.
18. Size: 4 foot tall by 24 foot wide (1219x7315mm) board.
19. Size: 5 foot tall by 6 foot wide (1524x1829mm) board.
20. Size: 5 foot tall by 8 foot wide (1524x2438mm) board.
21. Size: 5 foot tall by 10 foot wide (1524x3048mm) board.
22. Size: 5 foot tall by 12 foot wide (1524x3658mm) board.
23. Size: ___ foot tall by ___ foot wide (_____ x _____ mm) board.
24. Assembly: All boards are one piece up to 12 feet (3658mm) in length. When length exceeds 12 feet (3658mm), manufacturer's seam strip will be provided. Installation required at site.

F. Cork Bulletin Board: Self healing tack assembly composed of natural cork sheet factory laminated to a hardboard backing.

1. Face Sheet: Laminated 1/4 inch (6mm) thick natural cork sheet.
2. Backing Sheet: 3/8 inch (10mm) thick hardboard.
3. Size: 1 foot tall by 1 foot wide (304x304mm) board.
4. Size: 1-1/2 foot tall by 2 foot wide (457x609mm) board.
5. Size: 2 foot tall by 2 foot wide (609x609mm) board.
6. Size: 2 foot tall by 3 foot wide (609x914mm) board.
7. Size: 2 foot tall by 4 foot wide (609x1219mm) board.
8. Size: 3 foot tall by 4 foot wide (914x1219mm) board.
9. Size: 4 foot tall by 4 foot wide (1219x1219mm) board.
10. Size: 4 foot tall by 5 foot wide (1219x1560mm) board.
11. Size: 4 foot tall by 6 foot wide (1219x1829mm) board.
12. Size: 4 foot tall by 8 foot wide (1219x2438mm) board.
13. Size: 4 foot tall by 10 foot wide (1219x3048mm) board.
14. Size: 4 foot tall by 12 foot wide (1219x3658mm) board.
15. Size: 4 foot tall by 16 foot wide (1219x4877mm) board.
16. Size: 4 foot tall by 20 foot wide (1219x6096mm) board.
17. Size: 4 foot tall by 24 foot wide (1219x7315mm) board.
18. Size: ___ foot tall by ___ foot wide (_____ x _____ mm) board.
- 19.

2.3 BOARD CONFIGURATION

- A. Combination Board Style A: Two Panels - Vertical H-Channel.

1. Size: 1 foot tall by 1 foot wide (304x304mm) board.
2. Size: 1-1/2 foot tall by 2 foot wide (457x609mm) board.
3. Size: 2 foot tall by 2 foot wide (609x609mm) board.
4. Size: 2 foot tall by 3 foot wide (609x914mm) board.
5. Size: 2 foot tall by 4 foot wide (609x1219mm) board.
6. Size: 3 foot tall by 4 foot wide (914x1219mm) board.
7. Size: 4 foot tall by 4 foot wide (1219x1219mm) board.
8. Size: 4 foot tall by 5 foot wide (1219x1560mm) board.
9. Size: 4 foot tall by 6 foot wide (1219x1829mm) board.
10. Size: 4 foot tall by 8 foot wide (1219x2438mm) board.
11. Size: 4 foot tall by 10 foot wide (1219x3048mm) board.
12. Size: 4 foot tall by 12 foot wide (1219x3658mm) board.
13. Size: 4 foot tall by 16 foot wide (1219x4877mm) board.
14. Size: 4 foot tall by 20 foot wide (1219x6096mm) board.
15. Size: 4 foot tall by 24 foot wide (1219x7315mm) board.
16. Placement:
 - a. Left Side: Cork Bulletin Board.
 - b. Left Side: Dry Erase Board.
 - c. Right Side: Cork Bulletin Board.
 - d. Right Side: Dry Erase Board.

B. Combination Board Style B: Three Panels - Dual Vertical H-Channels.

1. Size: 3 foot tall by 3 foot wide (914x914mm) board.
2. Size: 4 foot tall by 4 foot wide (1219x1219mm) board.
3. Size: 4 foot tall by 6 foot wide (1219x1829mm) board
4. Size: 4 foot tall by 8 foot wide (1219x2438mm) board.
5. Size: 4 foot tall by 10 foot wide (1219x3048mm) board.
6. Size: 4 foot tall by 12 foot wide (1219x3658mm) board.
7. Size: 4 foot tall by 16 foot wide (1219x4877mm) board.
8. Size: 4 foot tall by 20 foot wide (1219x6096mm) board.
9. Size: 4 foot tall by 24 foot wide (1219x7315mm) board.
10. Placement:
 - a. Left Side: Cork Bulletin Board.
 - b. Center: Dry Erase Board.
 - c. Right Side: Cork Bulletin Board.

C. Combination Board Style C: 2 Panels – H-Channel, Overhead Bulletin Board.

1. Size: 2 foot tall by 2 foot wide (609x609mm) board.
2. Size: 3 foot tall by 3 foot wide (914x914mm) board.
3. Size: 4 foot tall by 4 foot wide (1219x1219mm) board.
4. Size: 4 foot tall by 6 foot wide (1219x1829mm) board
5. Size: 4 foot tall by 8 foot wide (1219x2438mm) board.
6. Size: 4 foot tall by 10 foot wide (1219x3048mm) board.
7. Size: 4 foot tall by 12 foot wide (1219x3658mm) board.
8. Size: 4 foot tall by 16 foot wide (1219x4877mm) board.
9. Size: 4 foot tall by 20 foot wide (1219x6096mm) board.
10. Size: 4 foot tall by 24 foot wide (1219x7315mm) board.
11. Size: ___ foot tall by ___ foot wide (_____ x _____ mm) board.
12. Placement:
 - a. Upper: Cork Bulletin Board.
 - b. Lower: Dry Erase Board.
 - c. H-Channel

D. Combination Board Style D: 4 Panels - Dual Vertical H-Channels, Horizontal H-Channel, and Overhead Bulletin Board.

1. Size: 4 foot tall by 4 foot wide (1219x1219mm) board.

2. Size: 4 foot tall by 6 foot wide (1219x1829mm) board
3. Size: 4 foot tall by 8 foot wide (1219x2438mm) board.
4. Size: 4 foot tall by 10 foot wide (1219x3048mm) board.
5. Size: 4 foot tall by 12 foot wide (1219x3658mm) board.
6. Size: 4 foot tall by 16 foot wide (1219x4877mm) board.
7. Size: 4 foot tall by 20 foot wide (1219x6096mm) board.
8. Size: 4 foot tall by 24 foot wide (1219x7315mm) board.
9. Size: ___ foot tall by ___ foot wide (_____ x _____ mm) board.
10. Placement:
 - a. Upper: Cork Bulletin Board.
 - b. Left Side: Cork Bulletin Board.
 - c. Center: Dry Erase Board.
 - d. Right Side: Cork Bulletin Board.
 - e. H-Channels.

E. Standard Graphic Boards: Graphics permanently laminated into dry erase board.

1. Graphic: Penmanship lines.
2. Graphic: Music staff lines.
3. Graphic: 1 inch (25mm) square grid lines.
4. Graphic: EZ Grid, Grid 1"
5. Graphic: EZ Grid, Grid 2"
6. Graphic: EZ Grid, Dot 1"
7. Graphic: EZ Grid, Dot 2"
8. Graphic: EZ Grid, ISO 1"
9. Graphic: EZ Grid, ISO 2"
10. Graphic: Standard Sport, Basketball
11. Graphic: Standard Sport, Hockey
12. Graphic: Standard Sport, Football
13. Graphic: Standard Sport, Soccer
14. Graphic: Standard Sport, Volleyball
15. Graphic: Calendars, 1, 2, 3, 4, 6 & 12 months and 1 month plus
16. Placement: Covering entire dry erase board.
17. Size: 1 foot tall by 1 foot wide (304x304mm) board.
18. Size: 1-1/2 foot tall by 2 foot wide (457x609mm) board.
19. Size: 2 foot tall by 2 foot wide (609x609mm) board.
20. Size: 2 foot tall by 3 foot wide (609x914mm) board.
21. Size: 2 foot tall by 4 foot wide (609x1219mm) board.
22. Size: 3 foot tall by 4 foot wide (914x1219mm) board.
23. Size: 4 foot tall by 4 foot wide (1219x1219mm) board.
24. Size: 4 foot tall by 5 foot wide (1219x1560mm) board.
25. Size: 4 foot tall by 6 foot wide (1219x1829mm) board.
26. Size: 4 foot tall by 8 foot wide (1219x2438mm) board.
27. Size: 4 foot tall by 10 foot wide (1219x3048mm) board.
28. Size: 4 foot tall by 12 foot wide (1219x3658mm) board.

F. Graphic Combination Boards: 4 foot by 4 foot (1219mm x 1219mm) graphic permanently laminated onto one side of the dry erase board. Remaining surface of the board remains plain.

1. Graphic: Penmanship lines.
2. Graphic: Music staff lines.
3. Graphic: 1 inch (25mm) square grid lines.
4. Graphic: EZ Grid, Grid 1"
5. Graphic: EZ Grid, Grid 2"
6. Graphic: EZ Grid, Dot 1"
7. Graphic: EZ Grid, Dot 2"
8. Graphic: EZ Grid, ISO 1"
9. Graphic: EZ Grid, ISO 2"
10. Graphic: Standard Sport, Basketball

11. Graphic: Standard Sport, Hockey
12. Graphic: Standard Sport, Football
13. Graphic: Standard Sport, Soccer
14. Graphic: Standard Sport, Volleyball
15. Graphic: Calendars, 1, 2, 3, 4, 6 & 12 months and 1 month plus
16. Graphic: _____
17. Size Restrictions: All graphics can be ordered in all available sizes.

18. Size: 4 foot tall by 4 foot wide (1219x1219mm) board.
19. Size: 4 foot tall by 5 foot wide (1219x1560mm) board.
20. Size: 4 foot tall by 6 foot wide (1219x1829mm) board.
21. Size: 4 foot tall by 8 foot wide (1219x2438mm) board.
22. Size: 4 foot tall by 10 foot wide (1219x3048mm) board.
23. Size: 4 foot tall by 12 foot wide (1219x3658mm) board.
24. Size: 4 foot tall by 16 foot wide (1219x4877mm) board.
25. Size: ____ foot tall by ____ foot wide (_____ x _____mm) board.
26. Assembly: All boards are one piece up to 12 feet (3658mm) in length. When length exceeds 12 feet (3658mm), manufacturer's H-Channel will be provided. Assembly required at site.

2.4 FRAMING

- A. Aluminum Frame and Marker Tray:
 1. Thickness: .719 inch (18mm) thick, extruded aluminum frame.
 2. Width: Narrow - 5/8 inch (15mm).
 3. Width: Wide – 1 1/8 inch (29mm).
 4. Marker Tray: 2 5/8 inch (67mm) Continuous solid extruded aluminum tray with 3 channels and protective plastic end caps.
 5. Finish: Satin Anodized clear finish.
 6. End Cap Color: Silver.

- B. Wood Frame and Marker Tray:
 1. Thickness: 0.875 inch (22mm) thick, solid wood frame.
 2. Width: Narrow – 1 1/4 inch (32mm).
 3. Width: Wide – 1 7/8 inch (48mm).
 4. Marker Tray: 1 7/8 inch (48mm) deep single channel tray.
 5. Wood Type: Natural Oak.
 6. Wood Type: Maple.
 7. Wood Type: Maple with Mahogany Stain.
 8. Wood Type: Maple with Cherry Stain.
 9. Wood Type: Maple with Black Paint.

2.5 ACCESSORIES

- A. Map Rail: Standard 1 inch (25mm) map rail with cork insert.
 1. Map Hooks and Clips: Extruded Aluminum.
 2. Flag Holder: Extruded Aluminum.
 3. Map Winders: Extruded Aluminum.

- B. Markers and Cleaning Cloths:
 1. Dry Erase Marker Set including red, blue, green and black.
 2. EverCloth - Reusable dry erase marking board cleaning cloth.

PART 3 EXECUTION

3.1 EXAMINATION AND PREPARATION

- A. Do not begin installation until substrates have been properly prepared.

B. If substrate preparation is the responsibility of another installer, notify Architect of unsatisfactory preparation before proceeding.

C. Clean surfaces thoroughly after installation with water or glass cleaner.

3.2 INSTALLATION

A. Install in accordance with manufacturer's instructions.

B. Install all units in locations shown on plans, at mounting heights specified on the Contract Drawings. Keep perimeter lines straight, plumb and level.

C. EVERWhite products are designed to be installation-ready, however, installation and the installation environment are out of EVERWhite's control and therefore installation is not warranted by EWhite in any circumstance.

3.3 CLEANING AND PROTECTION

A. Clean display boards prior to project closeout.

B. Protect installed products until completion of project.

C. Repair or replace damaged products before Substantial Completion.

END OF SECTION

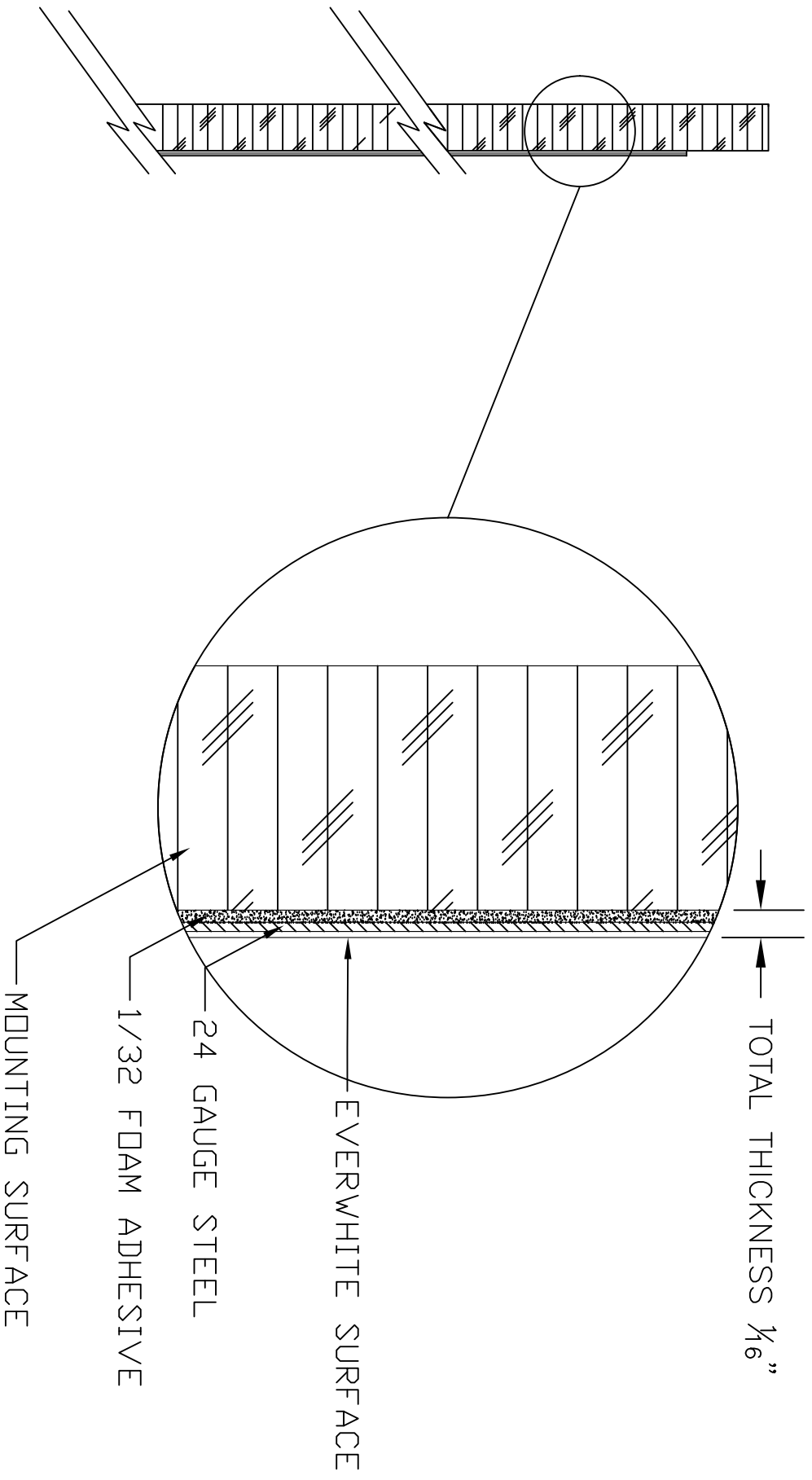

RESURFACING PANEL SIZES

- 1' x 1' CONSISTS OF ONE 1' PANEL
- 1.5' x 2' CONSISTS OF ONE 2' PANEL
- 2' x 2' CONSISTS OF ONE 2' PANEL
- 2' x 3' CONSISTS OF ONE 3' PANEL
- 2' x 4' CONSISTS OF ONE 4' PANEL
- 3' x 4' CONSISTS OF ONE 4' PANEL
- 4' x 4' CONSISTS OF ONE 4' PANEL
- 4' x 5' CONSISTS OF ONE 5' PANEL
- 4' x 6' CONSISTS OF ONE 6' PANEL
- 4' x 8' CONSISTS OF ONE 8' PANEL
- 4' x 10' CONSISTS OF ONE 10' PANEL
- 4' x 12' CONSISTS OF TWO 6' PANELS WITH A SEAM STRIP
- 4' x 16' CONSISTS OF TWO 10' PANELS WITH A SEAM STRIP
- 4' x 20' CONSISTS OF TWO 12' PANELS WITH A SEAM STRIP

IMPORTANT NOTICE
FIELD VERIFY ALL DIMENSIONS AND LOCATIONS PRIOR TO MANUFACTURING

QTY	SIZE	TYPE	LOCATION	ADDITIONAL COMMENTS

BOARD SCHEDULE

EVER White
184 RAILROAD DRIVE
WARRMINSTER, PA 18974
PH (600) 335-7319
FX (215) 323-4135

RESURFACING PANEL

REV. B

CUSTOMER SERVICE AND SUPPORT (800) 335-7319
WWW.EVERWHITEBOARDS.COM
MADE IN THE USA

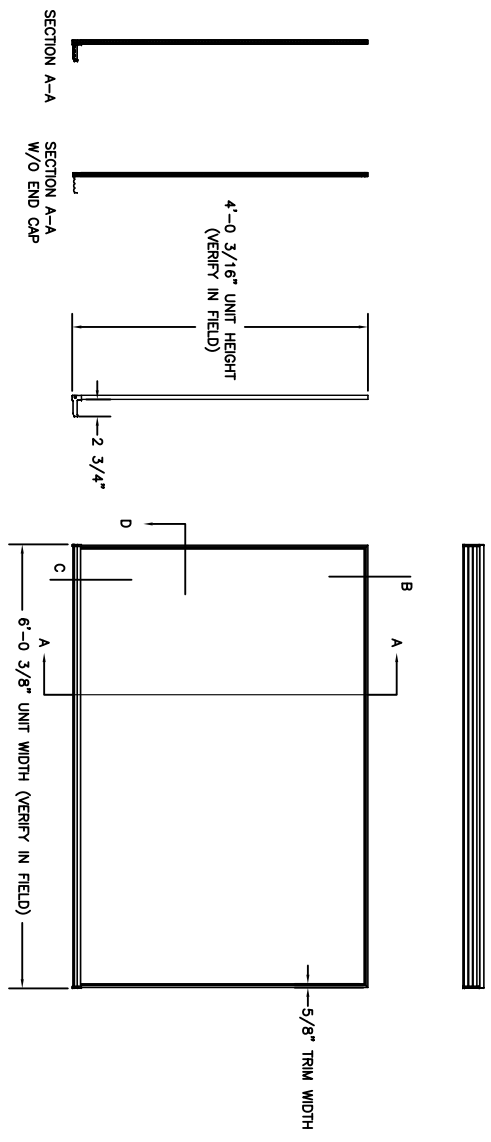
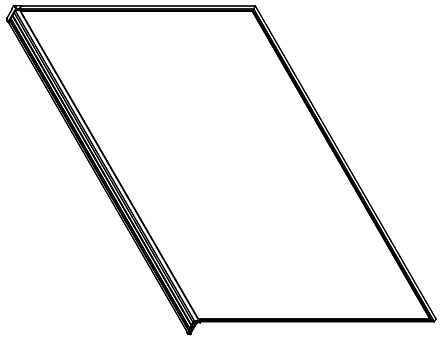

NOTE: RECOMMENDED MARKERBOARD MOUNTING HEIGHTS
 A) 2'4" FROM FLOOR FOR K-4th GRADE*
 B) 2'8" FROM FLOOR FOR 5th & 6th GRADE*
 C) 2'10" FROM FLOOR FOR 7th & 8th GRADE*
 D) 3'0" FROM FLOOR FOR HIGH SCHOOL*
 *(UNLESS OTHERWISE SPECIFIED BY ARCHITECT)

MARKERBOARD
 ELEVATION
 $3/8" = 1'-0"$

BOARD CONSTRUCTION TYPE:
 MAGNETIC
 NON-MAGNETIC
 CORK (TRAY NOT INCLUDED)

IMPORTANT NOTICE
 FIELD VERIFY ALL DIMENSIONS AND
 LOCATIONS PRIOR TO MANUFACTURING

ALUMINUM FRAMED BOARD SIZES
 FOR BOTH WIDE (1 1/8") & NARROW (3/8") FRAME STYLE

BOARD MAKE-UP

1' x 1'	CONSISTS OF ONE 1' BOARD
1.5' x 2'	CONSISTS OF ONE 2' BOARD
2' x 2'	CONSISTS OF ONE 2' BOARD
2' x 3'	CONSISTS OF ONE 3' BOARD
2' x 4'	CONSISTS OF ONE 4' BOARD
3' x 4'	CONSISTS OF ONE 4' BOARD
4' x 4'	CONSISTS OF ONE 4' BOARD
4' x 5'	CONSISTS OF ONE 5' BOARD
4' x 6'	CONSISTS OF ONE 6' BOARD
4' x 8'	CONSISTS OF ONE 8' BOARD
4' x 10'	CONSISTS OF ONE 10' BOARD
4' x 12'	CONSISTS OF ONE 12' BOARD
4' x 16'	CONSISTS OF TWO 8' BOARDS WITH H-CHANNEL
4' x 20'	CONSISTS OF TWO 10' BOARDS WITH H-CHANNEL
4' x 24'	CONSISTS OF TWO 12' BOARDS WITH H-CHANNEL

QTY	SIZE	TYPE	LOCATION	ADDITIONAL COMMENTS

BOARD SCHEDULE

EVER *White*
 184 RAILROAD DRIVE
 WARMINSTER, PA 18974
 PH (600) 335-7319
 FX (215) 323-4135

NARROW ALUMINUM FRAME PAGE 1 OF 2

REV. B

CUSTOMER SERVICE AND
 SUPPORT (800) 335-7319
 WWW.EVERWHITEBOARDS.COM
 MADE IN THE USA

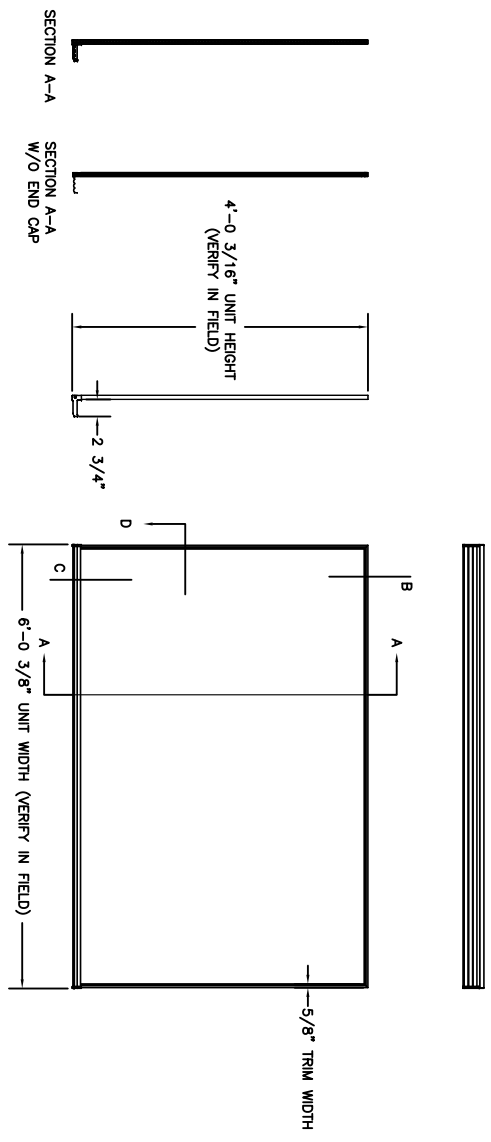
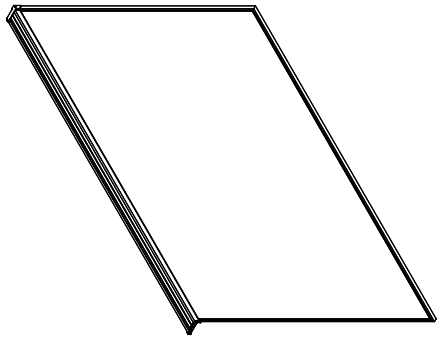

NOTE: RECOMMENDED MARKERBOARD MOUNTING HEIGHTS
 A) 2'4" FROM FLOOR FOR K-4th GRADE*
 B) 2'8" FROM FLOOR FOR 5th & 8th GRADE*
 C) 2'10" FROM FLOOR FOR 7th & 8th GRADE*
 D) 3'0" FROM FLOOR FOR HIGH SCHOOL*
 *(UNLESS OTHERWISE SPECIFIED BY ARCHITECT)

ALUMINUM FRAMED BOARD SIZES
 FOR BOTH WIDE (1 1/8") & NARROW (3/8") FRAME STYLE
 BOARD MAKE-UP

1' x 1'	CONSISTS OF ONE 1 BOARD
1.5' x 2'	CONSISTS OF ONE 2 BOARD
2' x 2'	CONSISTS OF ONE 2 BOARD
2' x 3'	CONSISTS OF ONE 3 BOARD
2' x 4'	CONSISTS OF ONE 4 BOARD
3' x 4'	CONSISTS OF ONE 4 BOARD
4' x 4'	CONSISTS OF ONE 4 BOARD
4' x 5'	CONSISTS OF ONE 5 BOARD
4' x 6'	CONSISTS OF ONE 6 BOARD
4' x 8'	CONSISTS OF ONE 8 BOARD
4' x 10'	CONSISTS OF ONE 10 BOARD
4' x 12'	CONSISTS OF ONE 12 BOARD
4' x 16'	CONSISTS OF TWO 8 BOARDS WITH H-CHANNEL
4' x 20'	CONSISTS OF TWO 10 BOARDS WITH H-CHANNEL
4' x 24'	CONSISTS OF TWO 12 BOARDS WITH H-CHANNEL
5' x 6'	CONSISTS OF ONE 6 BOARD
5' x 8'	CONSISTS OF ONE 8 BOARD
5' x 10'	CONSISTS OF ONE 10 BOARD
5' x 12'	CONSISTS OF ONE 12 BOARD

MARKERBOARD
 ELEVATION
 3/8" = 1'-0"

IMPORTANT NOTICE
 FIELD VERIFY ALL DIMENSIONS AND
 LOCATIONS PRIOR TO MANUFACTURING

- BOARD CONSTRUCTION TYPE:
- MAGNETIC
 - NON-MAGNETIC
 - CORK (TRAY NOT INCLUDED)

QTY	SIZE	TYPE	LOCATION	ADDITIONAL COMMENTS

BOARD SCHEDULE

EVER
 184 RAILROAD DRIVE
 WARMINSTER, PA 18974
 PH (600) 335-7319
 FX (215) 323-4135

CUSTOMER SERVICE AND
 SUPPORT (800) 335-7319
 WWW.EVERWHITEBOARDS.COM
 MADE IN THE USA

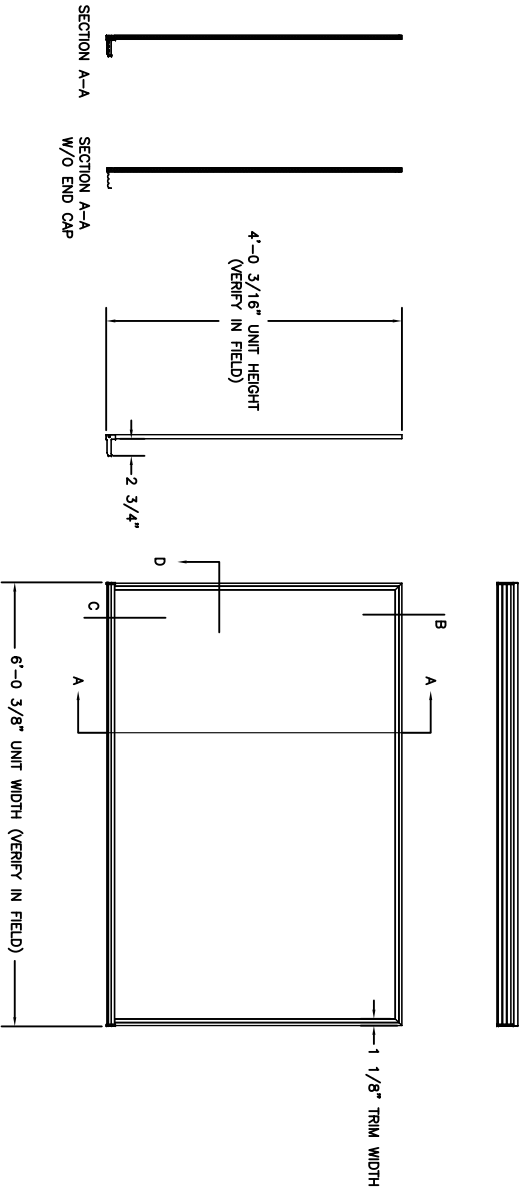
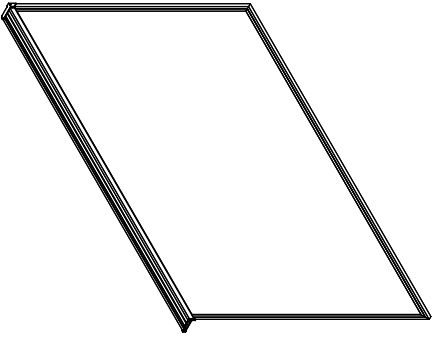

NOTE: RECOMMENDED MARKERBOARD MOUNTING HEIGHTS
 A) 2'4" FROM FLOOR FOR K-4th GRADE*
 B) 2'8" FROM FLOOR FOR 5th & 8th GRADE*
 C) 2'10" FROM FLOOR FOR 7th & 8th GRADE*
 D) 3'0" FROM FLOOR FOR HIGH SCHOOL*
 *(UNLESS OTHERWISE SPECIFIED BY ARCHITECT)

MARKERBOARD
 ELEVATION
 3/8" = 1'-0"

ALUMINUM FRAMED BOARD SIZES
 FOR BOTH WIDE (1 7/8") & NARROW (3/4") FRAME STYLE
 BOARD MAKE-UP

1' x 1'	CONSISTS OF ONE 1' BOARD
1'3" x 2'	CONSISTS OF ONE 2' BOARD
2' x 2'	CONSISTS OF ONE 2' BOARD
2' x 3'	CONSISTS OF ONE 3' BOARD
2' x 4'	CONSISTS OF ONE 4' BOARD
3' x 4'	CONSISTS OF ONE 4' BOARD
4' x 4'	CONSISTS OF ONE 4' BOARD
4' x 5'	CONSISTS OF ONE 5' BOARD
4' x 6'	CONSISTS OF ONE 6' BOARD
4' x 8'	CONSISTS OF ONE 8' BOARD
4' x 10'	CONSISTS OF ONE 10' BOARD
4' x 12'	CONSISTS OF ONE 12' BOARD
4' x 16'	CONSISTS OF TWO 8' BOARDS WITH H-CHANNEL
4' x 20'	CONSISTS OF TWO 10' BOARDS WITH H-CHANNEL
4' x 24'	CONSISTS OF TWO 12' BOARDS WITH H-CHANNEL

IMPORTANT NOTICE
 FIELD VERIFY ALL DIMENSIONS AND
 LOCATIONS PRIOR TO MANUFACTURING

BOARD CONSTRUCTION TYPE:
 MAGNETIC
 NON-MAGNETIC
 CORK (TRAY NOT INCLUDED)

QTY	SIZE	TYPE	LOCATION	ADDITIONAL COMMENTS

BOARD SCHEDULE

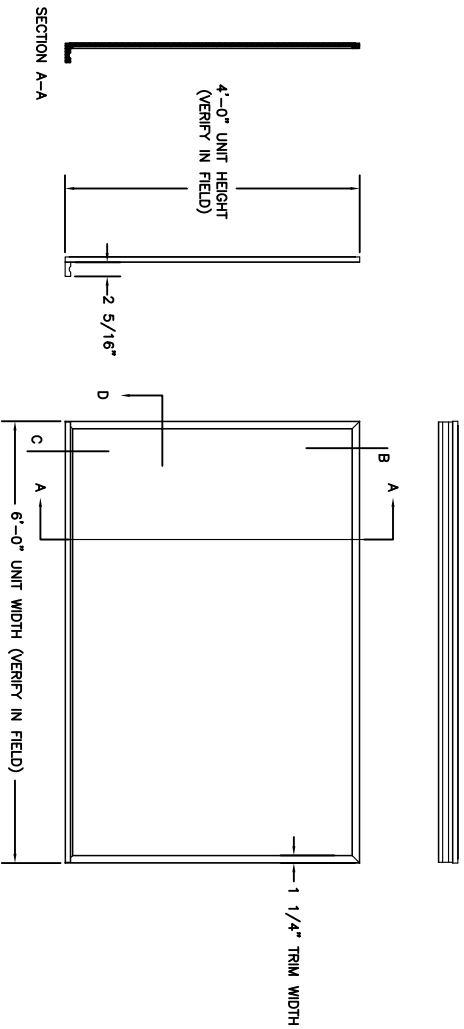
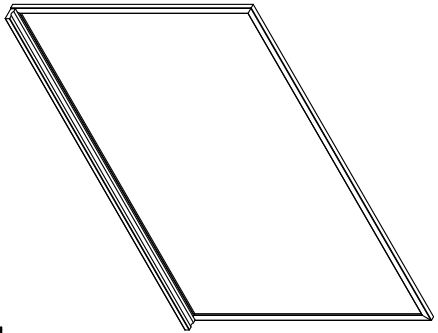

NOTE: RECOMMENDED MARKERBOARD MOUNTING HEIGHTS
 1) 2'-4" FROM FLOOR FOR K-4th GRADE*
 2) 2'-8" FROM FLOOR FOR 5th & 8th GRADE*
 3) 2'-10" FROM FLOOR FOR 7th & 8th GRADE*
 4) 3'-0" FROM FLOOR FOR HIGH SCHOOL*
 *(UNLESS OTHERWISE SPECIFIED BY ARCHITECT)

MARKERBOARD
 ELEVATION
 3/8" = 1'-0"

WOOD FRAMED BOARD SIZES
 FOR NARROW (1 1/4") FRAME STYLE

SIZE

BOARD MAKE-UP

- 1.5' x 2' CONSISTS OF ONE 2' BOARD
- 2' x 2' CONSISTS OF ONE 2' BOARD
- 2' x 3' CONSISTS OF ONE 3' BOARD
- 2' x 4' CONSISTS OF ONE 4' BOARD
- 3' x 4' CONSISTS OF ONE 4' BOARD
- 4' x 4' CONSISTS OF ONE 4' BOARD
- 4' x 6' CONSISTS OF ONE 6' BOARD

IMPORTANT NOTICE
 FIELD VERIFY ALL DIMENSIONS AND
 LOCATIONS PRIOR TO MANUFACTURING

- BOARD CONSTRUCTION TYPE:
- MAGNETIC
 - NON-MAGNETIC
 - CORK (TRAY NOT INCLUDED)

QTY	SIZE	TYPE	LOCATION	ADDITIONAL COMMENTS

BOARD SCHEDULE

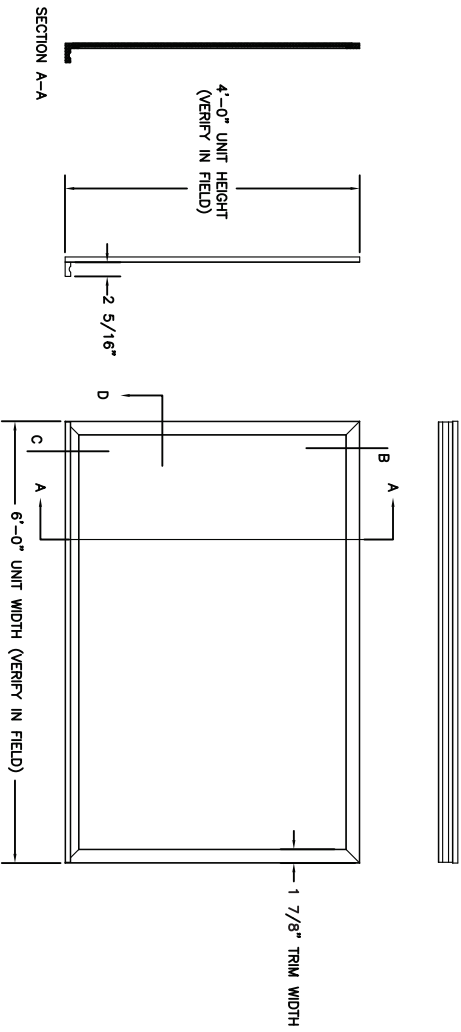
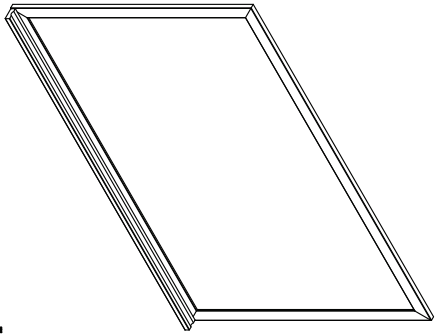

NOTE: RECOMMENDED MARKERBOARD MOUNTING HEIGHTS
 A) 2'-4" FROM FLOOR FOR K-4th GRADE*
 B) 2'-8" FROM FLOOR FOR 5th & 6th GRADE*
 C) 2'-10" FROM FLOOR FOR 7th & 8th GRADE*
 D) 3'-0" FROM FLOOR FOR HIGH SCHOOL*
 *(UNLESS OTHERWISE SPECIFIED BY ARCHITECT)

WIDE WOOD FRAME FRAME STYLE (1 7/8")

BOARD MAKE-UP

1' x 1'	CONSISTS OF ONE 1 BOARD
1.5' x 2'	CONSISTS OF ONE 2 BOARD
2' x 2'	CONSISTS OF ONE 2 BOARD
2' x 3'	CONSISTS OF ONE 3 BOARD
2' x 4'	CONSISTS OF ONE 4 BOARD
3' x 4'	CONSISTS OF ONE 4 BOARD
4' x 4'	CONSISTS OF ONE 4 BOARD
4' x 5'	CONSISTS OF ONE 5 BOARD
4' x 6'	CONSISTS OF ONE 6 BOARD
4' x 8'	CONSISTS OF ONE 8 BOARD
4' x 10'	CONSISTS OF ONE 10 BOARD
4' x 12'	CONSISTS OF ONE 12 BOARD
4' x 16'	CONSISTS OF TWO 8 BOARDS WITH H-CHANNEL
4' x 20'	CONSISTS OF TWO 10 BOARDS WITH H-CHANNEL
4' x 24'	CONSISTS OF TWO 12 BOARDS WITH H-CHANNEL

MARKERBOARD
 ELEVATION
 3/8" = 1'-0"

IMPORTANT NOTICE:
 FIELD VERIFY ALL DIMENSIONS AND
 LOCATIONS PRIOR TO MANUFACTURING

- BOARD CONSTRUCTION TYPE:
- MAGNETIC
 - NON-MAGNETIC
 - CORK (TRAY NOT INCLUDED)

QTY	SIZE	TYPE	LOCATION	ADDITIONAL COMMENTS

BOARD SCHEDULE

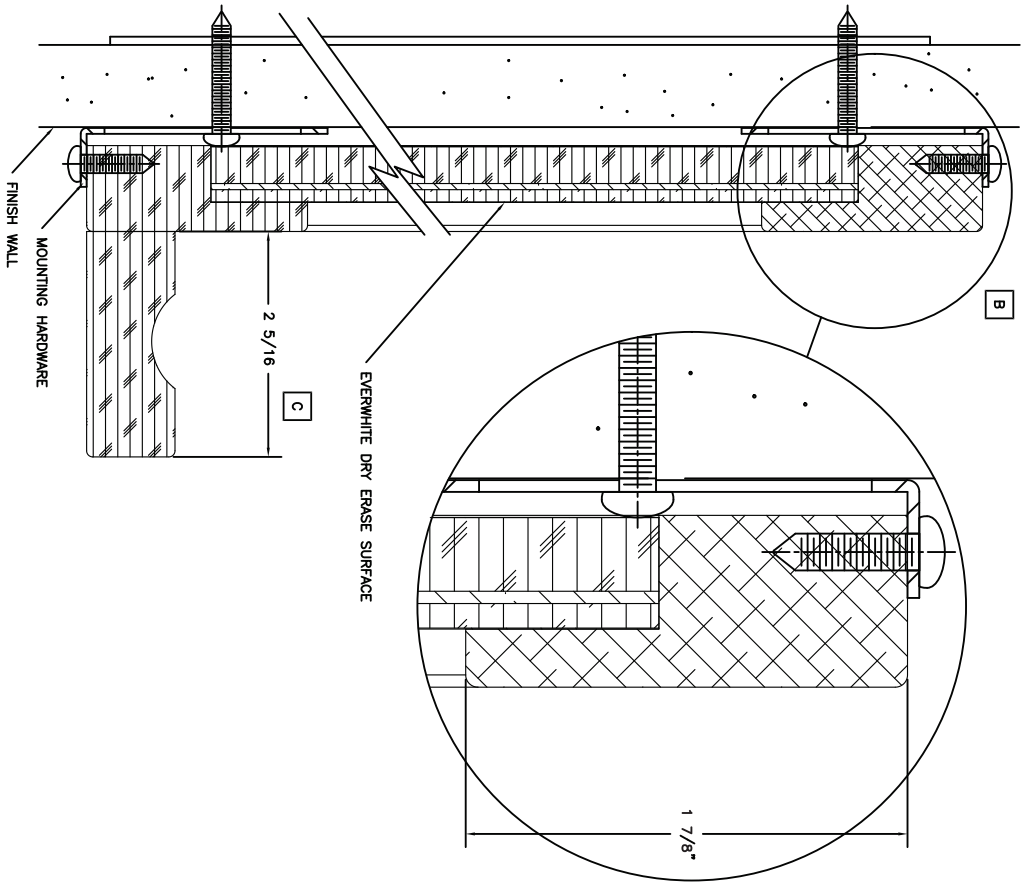

VERTICAL SECTIONS

DETAIL VIEWS NOT TO SCALE

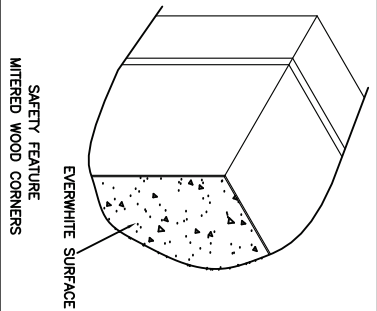

SAFETY FEATURE
MITERED WOOD CORNERS

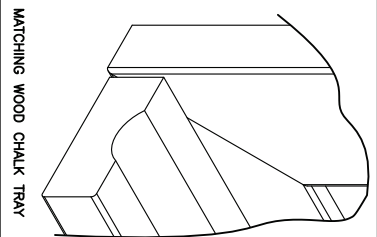

MATCHING WOOD CHALK TRAY

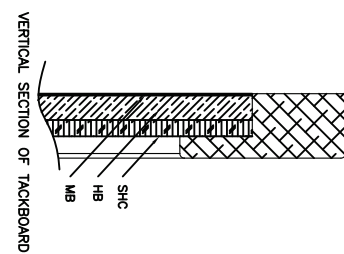

VERTICAL SECTION OF TACKBOARD

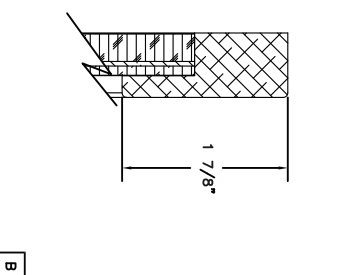

B

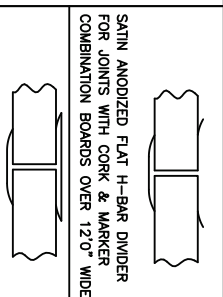

SATIN ANODIZED FLAT H-BAR DIVIDER FOR JOINTS WITH CORK & MARKER COMBINATION BOARDS OVER 12.0" WIDE



DRY ERASE RESISTANT PAINTED H-BAR DIVIDER FOR JOINTS BETWEEN MARKERBOARDS OVER 12.0" WIDE

QTY	PART NUMBER / DESCRIPTION	ADDITIONAL COMMENTS

ACCESSORIES SCHEDULE

EVERWHITE COMBINATION BOARDS
 -STANDARD SIZES UP TO 4' X 12' WITH VIRTUALLY UNLIMITED CUSTOM SIZES AVAILABLE
 -AVAILABLE WITH SELF-HEALING CORK OR VINYL IN MULTIPLE CONFIGURATIONS
 -AVAILABLE WITH CUSTOM GRAPHICS IN MULTIPLE CONFIGURATIONS
100% SOLID WOOD FRAME IN OAK OR MAPLE
STANDARD FINISH OPTIONS:
 -OAK
 -MAPLE
 -STAINED CHERRY
 -STAINED MAHOGANY
 -PAINTED BLACK
 -CUSTOM STAIN OPTIONS AVAILABLE UPON REQUEST

EVERWHITE MARKERBOARD FACE/CORE/BACKING
MAGNETIC
 01 EMS / 24GS / 1/2" HEX / MB
NON-MAGNETIC
 02 EMS / 1/8" HB / 3/8" HEX / MB

CORK TACKBOARDS FACE/CORE/BACKING
 01 1/4" SHC / 1/4" HB / MB

SHC - SELF-HEALING CORK
 HB - HARD BOARD
 MB - MOISTURE BARRIER SHEET

NOTE:
 CORK BOARDS DO NOT INCLUDE TRAY

EVER *White*

184 RAILROAD DRIVE
 WARMINSTER, PA 18974
 PH (600) 335-7319
 FX (215) 323-4135

CUSTOMER SERVICE AND SUPPORT (800) 335-7319
 WWW.EVERWHITEBOARDS.COM
 MADE IN THE USA

WIDE WOOD FRAME PAGE 2 OF 2

REV. B

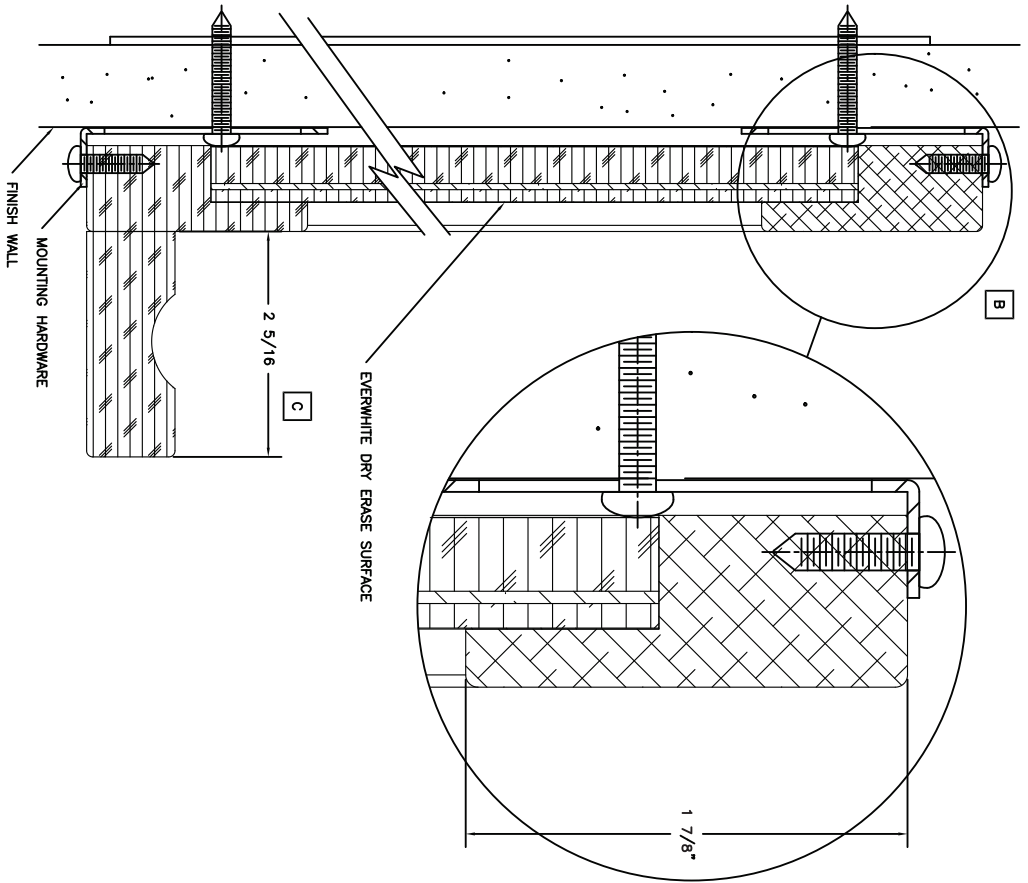

VERTICAL SECTIONS

DETAIL VIEWS NOT TO SCALE

SAFETY FEATURE
MITERED WOOD CORNERS

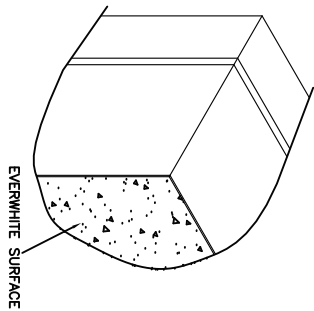

MATCHING WOOD CHALK TRAY

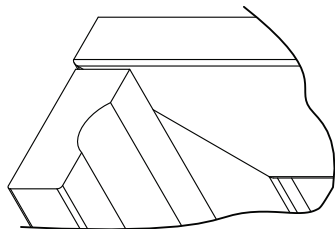

VERTICAL SECTION OF TACKBOARD

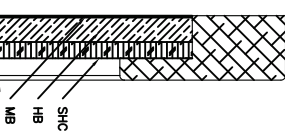

B

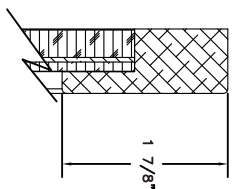

QTY	PART NUMBER / DESCRIPTION	ADDITIONAL COMMENTS

ACCESSORIES SCHEDULE

EVERWHITE COMBINATION BOARDS

- STANDARD SIZES UP TO 4' X 12' WITH VIRTUALLY UNLIMITED CUSTOM SIZES AVAILABLE
- AVAILABLE WITH SELF-HEALING CORK OR VINYL IN MULTIPLE CONFIGURATIONS
- AVAILABLE WITH CUSTOM GRAPHICS IN MULTIPLE CONFIGURATIONS

100% SOLID WOOD FRAME IN OAK OR MAPLE

- STANDARD FINISH OPTIONS:
 - OAK
 - MAPLE
 - STAINED CHERRY
 - STAINED MAHOGANY
 - PAINTED BLACK
- CUSTOM STAIN OPTIONS AVAILABLE UPON REQUEST

EVERWHITE MARKERBOARD

FACE/CORE/BACKING

MAGNETIC

- 01 EMS / 24GS / 1/2" HEX / MB

NON-MAGNETIC

- 02 EMS / 1/8" HB / 3/8" HEX / MB

CORK TACKBOARDS

FACE/CORE/BACKING

- 01 1/4" SHC / 1/4" HB / MB

- SHC - SELF-HEALING CORK
- HB - HARD BOARD
- MB - MOISTURE BARRIER SHEET

NOTE:
CORK BOARDS DO NOT INCLUDE TRAY



SATIN ANODIZED FLAT H-BAR DIVIDER FOR JOINTS WITH CORK & MARKER COMBINATION BOARDS OVER 12.0" WIDE

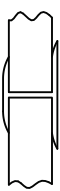

DRY ERASE RESISTANT PAINTED H-BAR DIVIDER FOR JOINTS BETWEEN MARKERBOARDS OVER 12.0" WIDE



Cork-Whiteboard Combination Board Dimensions

All measurements in feet, height x width

Style A Combination Board Dimensions – Cork on Either Side

Left Cork Version

Item Size	Left Cork	Whiteboard		
4 x 4	4 x 2	4 x 2		
4 x 6	4 x 2	4 x 4		
4 x 8	4 x 4	4 x 4		
4 x 10	4 x 4	4 x 6		
4 x 12	4 x 4	4 x 8		
4 x 16	4 x 4	4 x 12		

Right Cork Version

Item Size	Whiteboard	Right Cork		
4 x 4	4 x 2	4 x 2		
4 x 6	4 x 4	4 x 2		
4 x 8	4 x 4	4 x 4		
4 x 10	4 x 6	4 x 4		
4 x 12	4 x 8	4 x 4		
4 x 16	4 x 12	4 x 4		

Style B Combination Board Dimensions – Cork on Both Sides

Item Size	Left Cork	Whiteboard	Right Cork	
4 x 8	4 x 2	4 x 4	4 x 2	
4 x 10	4 x 2	4 x 6	4 x 2	
4 x 12	4 x 2	4 x 8	4 x 2	
4 x 16	4 x 4	4 x 8	4 x 4	

See Style C and D dimensions on next page.

Style C Combination Board Dimensions – Cork on Top

(1-inch map rail runs along the base of the cork panel)

Item Size	Whiteboard	Top Cork	
4 x 4	3 x 4	1 x 4	
4 x 6	3 x 6	1 x 6	
4 x 8	3 x 8	1 x 8	
4 x 10	3 x 10	1 x 10	
4 x 12	3 x 12	1 x 12	
4 x 16	3 x 16	1 x 16	<i>(whiteboard area is two 8' sections joined by an H channel)</i>

Style D Combination Board Dimensions – Cork on Top and Both Sides

(1-inch map rail runs along the base of the cork panel)

Item Size	Left Cork	Whiteboard	Right Cork	Top Cork
4 x 8	3 x 2	3 x 4	3 x 2	1 x 8
4 x 10	3 x 2	3 x 6	3 x 2	1 x 10
4 x 12	3 x 2	3 x 8	3 x 2	1 x 12
4 x 16	3 x 4	3 x 8	3 x 4	1 x 16



Take Off Sheet

Date: _____ PG# _____ OF: _____

Att: Estimating

Rm#	Qty.	Rm#	Qty.	Rm#	Qty.
_____ ()	_____ ()	_____ ()	_____ ()	_____ ()	_____ ()
_____ ()	_____ ()	_____ ()	_____ ()	_____ ()	_____ ()
_____ ()	_____ ()	_____ ()	_____ ()	_____ ()	_____ ()
_____ ()	_____ ()	_____ ()	_____ ()	_____ ()	_____ ()
_____ ()	_____ ()	_____ ()	_____ ()	_____ ()	_____ ()
TOTAL _____					
_____ ()	_____ ()	_____ ()	_____ ()	_____ ()	_____ ()
_____ ()	_____ ()	_____ ()	_____ ()	_____ ()	_____ ()
_____ ()	_____ ()	_____ ()	_____ ()	_____ ()	_____ ()
_____ ()	_____ ()	_____ ()	_____ ()	_____ ()	_____ ()
_____ ()	_____ ()	_____ ()	_____ ()	_____ ()	_____ ()
TOTAL _____					
_____ ()	_____ ()	_____ ()	_____ ()	_____ ()	_____ ()
_____ ()	_____ ()	_____ ()	_____ ()	_____ ()	_____ ()
_____ ()	_____ ()	_____ ()	_____ ()	_____ ()	_____ ()
_____ ()	_____ ()	_____ ()	_____ ()	_____ ()	_____ ()
_____ ()	_____ ()	_____ ()	_____ ()	_____ ()	_____ ()
TOTAL _____					

CIRCLE BOARD CHOICES BELOW:

Board Surface	Cork Color Options	Trim Options	Roll Options																																								
<ul style="list-style-type: none"> •High Gloss Dry Erase Whiteboard •High Gloss Dry Erase Resurfacing Panel •ULTimatte Projection Board •ULTimatte Projection Resurfacing Panel •Forbo® Cork •Custom Printed 	<table style="width:100%; text-align: center;"> <tr> <td></td> <td></td> <td></td> <td></td> <td></td> </tr> <tr> <td>Autumn</td> <td>Charcoal</td> <td>Chili Pepper</td> <td>Cinnamon</td> <td>Clay</td> </tr> <tr> <td></td> <td></td> <td></td> <td></td> <td></td> </tr> <tr> <td>Cobalt Blue</td> <td>Fog</td> <td>Grass</td> <td>Natural</td> <td>Sand</td> </tr> <tr> <td></td> <td></td> <td></td> <td></td> <td></td> </tr> <tr> <td>Slate</td> <td>Stone</td> <td>Timber Wolf</td> <td>Wheat</td> <td>White Stone</td> </tr> </table>						Autumn	Charcoal	Chili Pepper	Cinnamon	Clay						Cobalt Blue	Fog	Grass	Natural	Sand						Slate	Stone	Timber Wolf	Wheat	White Stone	<ul style="list-style-type: none"> •5/8" narrow aluminum •1-1/8" wide aluminum <table style="width:100%; text-align: center;"> <tr> <td></td> <td></td> <td></td> <td></td> <td></td> </tr> <tr> <td>Oak</td> <td>Maple</td> <td>Cherry</td> <td>Mahogany</td> <td>Black</td> </tr> </table> <ul style="list-style-type: none"> •1-1/4" narrow wood •1-7/8" wide wood 						Oak	Maple	Cherry	Mahogany	Black	<ul style="list-style-type: none"> •With marker tray •Without marker tray •1" map and display Rail (shown below)
Autumn	Charcoal	Chili Pepper	Cinnamon	Clay																																							
Cobalt Blue	Fog	Grass	Natural	Sand																																							
Slate	Stone	Timber Wolf	Wheat	White Stone																																							
Oak	Maple	Cherry	Mahogany	Black																																							

NOTE: Fill in dotted lines and indicate board type as follows:

TB=Tack Board, MB=Markerboard

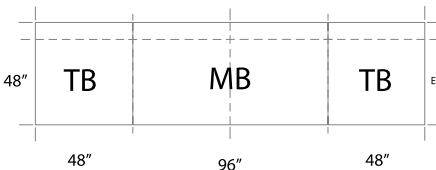

Job Name _____ Consignee Zip Code _____ ETA of Project _____

Distributor Name _____ Architect's Name _____

Estimator _____ Architect's Address _____

Phone _____

EVERWhite Whiteboards

Whiteboards | Resurfacing Solutions | Corkboards

Please include specifications. Additional copies are available on our website, www.everwhiteboards.com Call us at 800.335.7319